

Main Drive Components

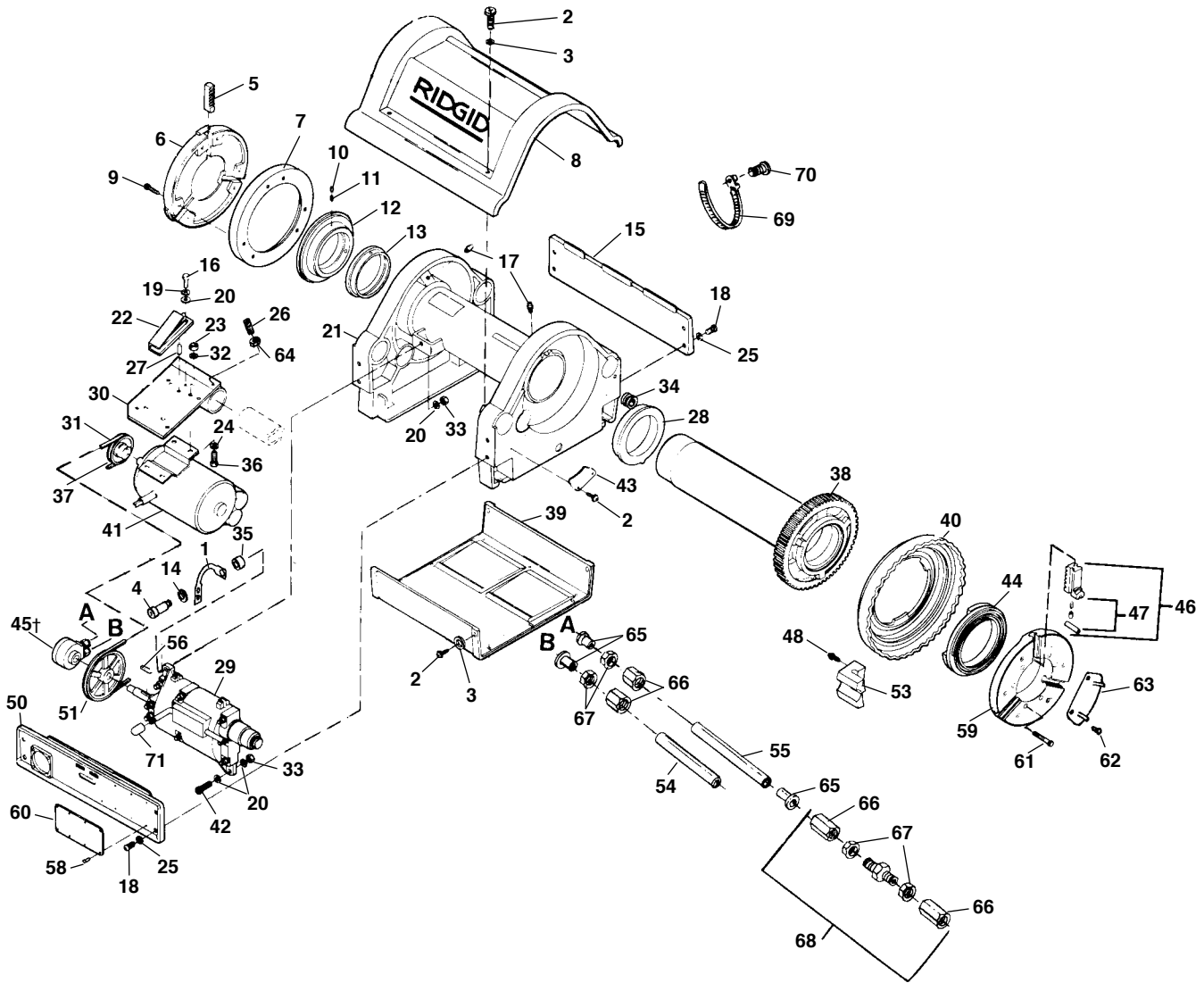

**NOTE: Order parts by Catalog Number only.
DO NOT order by Reference Number.**

Ref. No.	Catalog No.	Description	Ref. No.	Catalog No.	Description	Ref. No.	Catalog No.	Description
1	33622	Pump Bracket	25	40930	Lock Washer 3/8" (8)	45†	27307	Oil Pump
2	41597	Screw (12)	26	88265	Set Screw 3/16" - 16 x 1"	46	40087	Chuck Jaw Set
3	41592	Washer (10)	27	88230	Roll Pin 1/4" x 3/16"	47	26242	Jaw Insert Set
4	33627	Screw	28	26767	Front Bearing	26247	26247	Jaw Insert Set F/Coated Pipe
5	32412	Centering Jaw Set	29	26362	Gear Box Assy.	48	27067	Self-Tapping Screw (2 Req. f/G.S.)
6	26537	Centering Head	30	27062	Motor Bracket	50	59722	Front Side Plate
7	26542	Back Plate	31	26832	V-Belt	51	26852	Gear Box Pulley
8	26477	Top Cover	32	40770	Lock Washer 5/16" (4)	53	26507	Pinch Point Boss (2 Req. f/G.S.)
	46867	Die Head Decal (Not Shown)	33	27517	Lock Nut 5/16" - 18	54	27007	Inlet Hose
9	40910	Screw 1/4" - 20 x 3/4" (6)	34	47080	Grommet	55	26822	Output Hose
10	45300	Set Screw 5/16" - 24 x 1/4" (3)	35	33617	Spacer	56	27002	Key
11	45265	Set Screw 5/16" - 24 x 1/2" (3)	36	85910	Bolt 5/16" - 18 x 1 1/4"	58	85920	Rivets (8)
12	32407	Scroll	37	26857	Motor Pulley (60 Hz)	59	26332	Chuck Cap
13	26352	Rear Bearing		27082	Motor Pulley (50 Hz)	60	88690	Safety Plate
14	26307	Washer	38	26347	Drive Gear/Spindle Assy.	61	26522	Screw 5/16" - 24 x 2 1/4" (6)
15	26487	Rear Side Plate	39	26482	Bottom Cover	62	27242	Screw 10 - 32 (6)
16	32145	Screw 1/4" - 20 x 1/2"	40	26337	Handwheel	63	33612	Set of 3 Cover Plates
17	46860	Grease Fitting (2)	41	26237	Motor w/Capacitor 120V, 60 Hz	64	83545	Jam Nut 3/8" - 16
18	26997	Screw 3/8" - 16 x 3/4" (8)		27287	Motor w/Capacitor 110V, 50 Hz	65	35117	Tube Insert (3)
19	44740	Lock Washer 1/4"		26232	Motor w/Capacitor 240V, 60 Hz	66	40602	Compression Nut
20	96740	Washer 5/16"		27282	Motor w/Capacitor 220/240V, 50 Hz	67	40607	Ferrule
21	26357	Base		28052	Motor w/Capacitor 220V, 50 Hz GS	68	26972	Union
22	26492	Belt Tensioner	42	27037	Shoulder Bolt	69	43552	Tie Down Strap
23	96730	Nut 5/16" - 18 (4)	43	27012	Pinion Guard	70	45275	Screw 10 - 24 x 1/2"
24	27402	Washer 5/16" (4)	44	26517	Scroll	71	27032	Shifter Knob

†See Service Notes

Carriage and Chip Pan

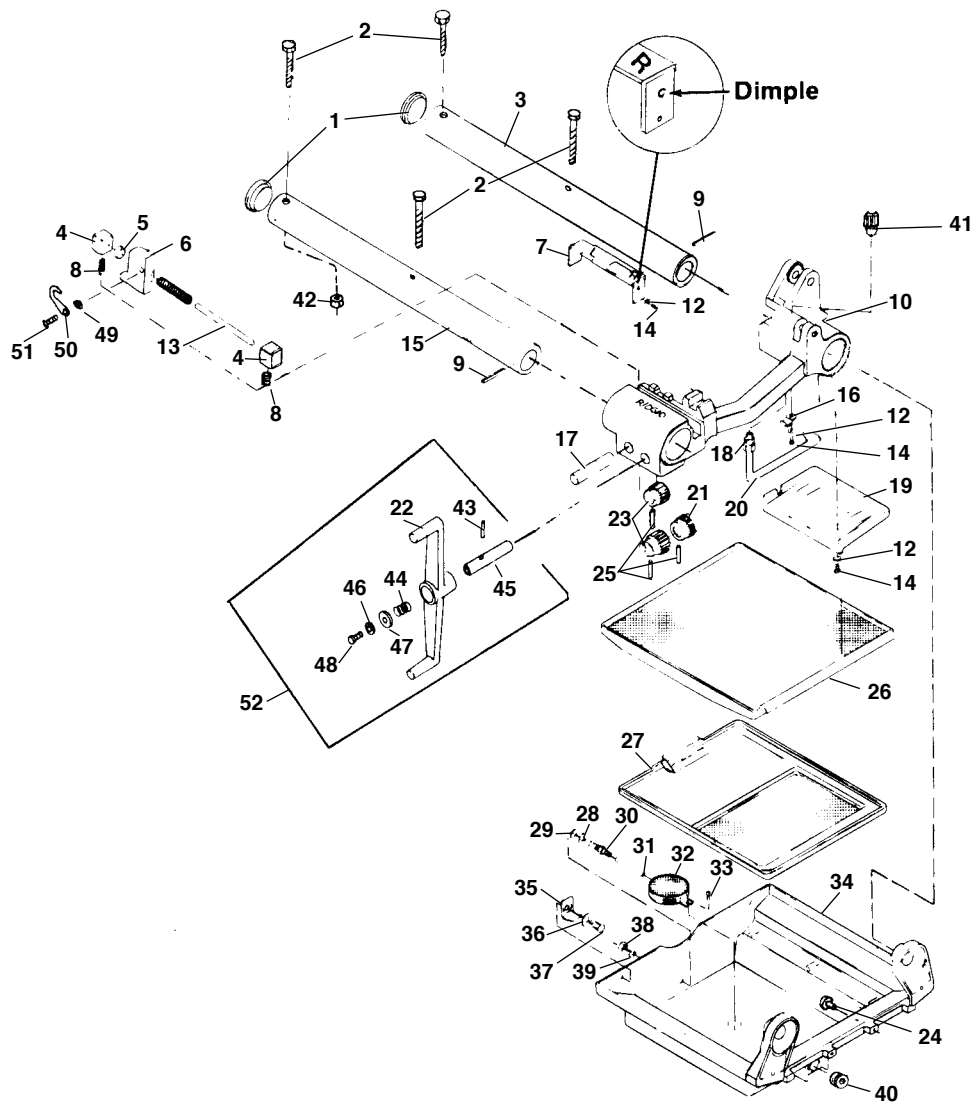

**NOTE: Order parts by Catalog Number only.
DO NOT order by Reference Number.**

Ref. No.	Catalog No.	Description	Ref. No.	Catalog No.	Description	Ref. No.	Catalog No.	Description
—	49992	Carriage Assembly (Includes Ref. #4-8, 10-14, 17, 21, 23, 25, 41, 49-52)	17	26777	Sine Bar/Pinion Shaft (2)	36	40930	Lock Washer 3/8" (2)
1	26502	Rail Plug (2)	18	26562	Supply Line Fitting	37	26997	Screw 3/8" - 16 x 3/4" (2)
2	40167	Bolt 5/16" - 18 x 3 1/2" (4)	19	26772	Drip Plate	38	83545	Hex Nut 3/8" - 16
3	49982	Rear Rail	20	26812	Die Lubrication Tube	39	26307	Washer
4	26787	Guide Block (2)	21	26587	Sine Bar Pinion	40	48337	Drain Plug
5	26792	Sine Bar Spacer	22	40147	Carriage Handwheel	41	28462	Ball Detente
6	40242	Sine Bar	23	26572	Carriage Pinion (2)	42	27517	Lock Nut 5/16" - 18 (4)
7	26912	Sine Bar Cover Assembly	24	26837	Stud (2)	43	74965	Pin
8	26582	Guide Block Spring (2)	25	74965	Roll Pin 1/4" x 1 1/4" (3)	44	89530	Spring
9	27052	Roll Pin (2)	26	26802	Draw Tray Assembly	45	40157	Handwheel Shaft
10	49987	Carriage (Includes Ref. #41)	27	26807	Insert Assembly	46	41582	Lock Washer
11	26592	Sine Bar Return Spring	28	27252	Washer	47	40152	Washer
12	41592	Washer #10 (2)	29	41715	Seal Washer	48	26997	Screw
13	26577	Guide Bar	30	26697	Bulk Head Fitting	49	40227	Spring Washer
14	79965	Screw #10 - 32 x 1/2" (5)	31	26927	Tubing	50	40237	Latch
15	49977	Front Rail	32	27262	Screen Assembly	51	40232	Spiral Pin
16	26652	Oil Supply Clamp	33	26797	Screw #10 - 32 x 5/16"	52	42027	Handwheel Kit
			34	26847	Chip Pan Hanger Assembly			
			35	26817	Chip Pan Bracket (2)			

Nos. 711 & 911 Self-Opening Die Heads

**NOTE: Order parts by Catalog Number only.
DO NOT order by Reference Number.**

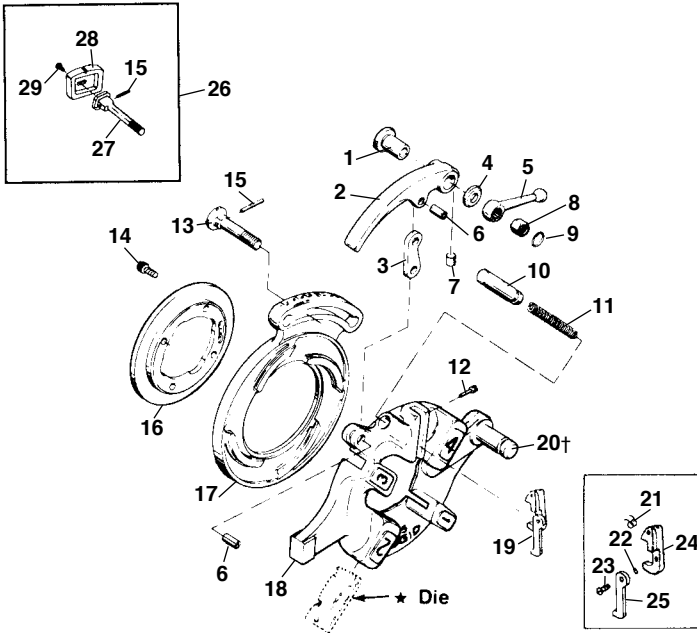

Ref. No.	Catalog No.	Description
—	26132	711 Self-Opening Die Head (NPT)
—	26137	911 Self-Opening Die Head (BSPT)
—	41382	911 Self-Opening Die Head f/Japan (BSPT)
—	46862	911 Self-Opening Die Head f/Europe
1	44240	Bushing
2	43830	Throw-out Lever
3	44265	Throw-out Link
4	44245	Thrust Washer
5	44260	Clamp Lever
6	44270	Spiral Pin
7	45055	Insert
8	44250	Nut
9	44255	Retaining Ring
10	44275	Throw-out Plunger
11	11565	Spring
12	44290	Trigger Screw
13	44235	Lock Screw
14	32205	Screw 1/4" - 20 x 5/8"
15	45050	Pin
16	97020	Retaining Ring
17	40942	Cam Plate (NPT)
	97040	Cam Plate (BSPT)
18	26717	Head w/Post
19	44285	Trigger Assy.
	32982	Adjustable Trigger Assy. (Europe)
	44687	Stepped Trigger Assy. (Japan)
†20	59827	Post
21	39982	Spring
22	44460	O-Ring
23	39967	Screw (Left Hand)
24	39977	Trigger Pivot
25	39972	Adjustable Trigger (Europe)
	44672	Stepped Trigger (Japan)
	45327	Stepped Trigger (Europe)
26	45332	Adj. Gage Plate Assy.
27	46722	Adj. Lock Screw
28	46717	Adj. Gage Plate
29	47147	Button Head Screw

† - See Service Notes

Nos. 714 & 914 Self-Opening Receding Die Heads

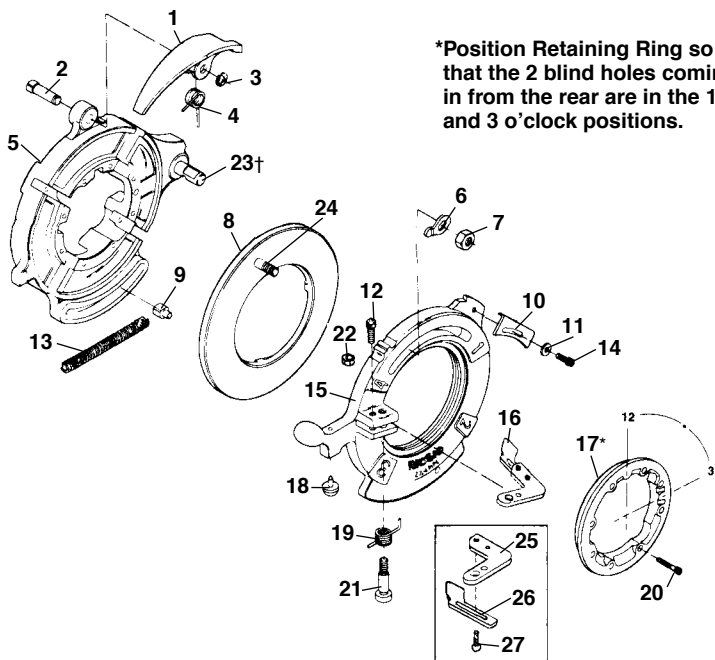

Ref. No.	Catalog No.	Description
—	26152	714 Self-Opening Receding Die Head (NPT)
—	26157	914 Self-Opening Receding Die Head (BSPT)
—	41387	914 Self-Opening Receding Die Head (BSPT) w/Adjustable Trigger
1	26877	Release Lever
2	26932	Groove Pin
3	26937	Retaining Ring
4	26872	Spring
5	26712	Die Head w/Post
6	26957	Lever Washer
7	26887	Hex Nut 7/16" - 20
8	26952	Cam Assy. (NPT)
	27277	Cam Assy. (BSPT)
9	26632	Drive Block
10	26867	Lockout Plate
11	27097	Washer 9/32"
12	27357	Screw 1/4" - 20 x 7/8"
13	26612	Drive Block Spring
14	32145	Screw 1/4" - 20 x 1/2"
15	26882	Cam Locking Plate
16	26617	Release Foot (NPT)
	32507	Release Foot (BSPT)
	32977	Adjustable Release Foot (BSPT)
*17	26637	Retaining Ring
18	26962	Sine Bar Ball
19	26622	Torsion Spring
20	26642	Screw #10 - 32 x 1 3/8" (8)
21	26627	Shoulder Bolt
22	77710	Hex Nut 1/4" - 20
†23	59827	Post
24	33227	Cam Bolt
25	39992	Release Foot Pivot
26	39987	Release Foot (BSPT)
27	32205	Screw

† - See Service Notes

No. 725 Cut Groove Die Head

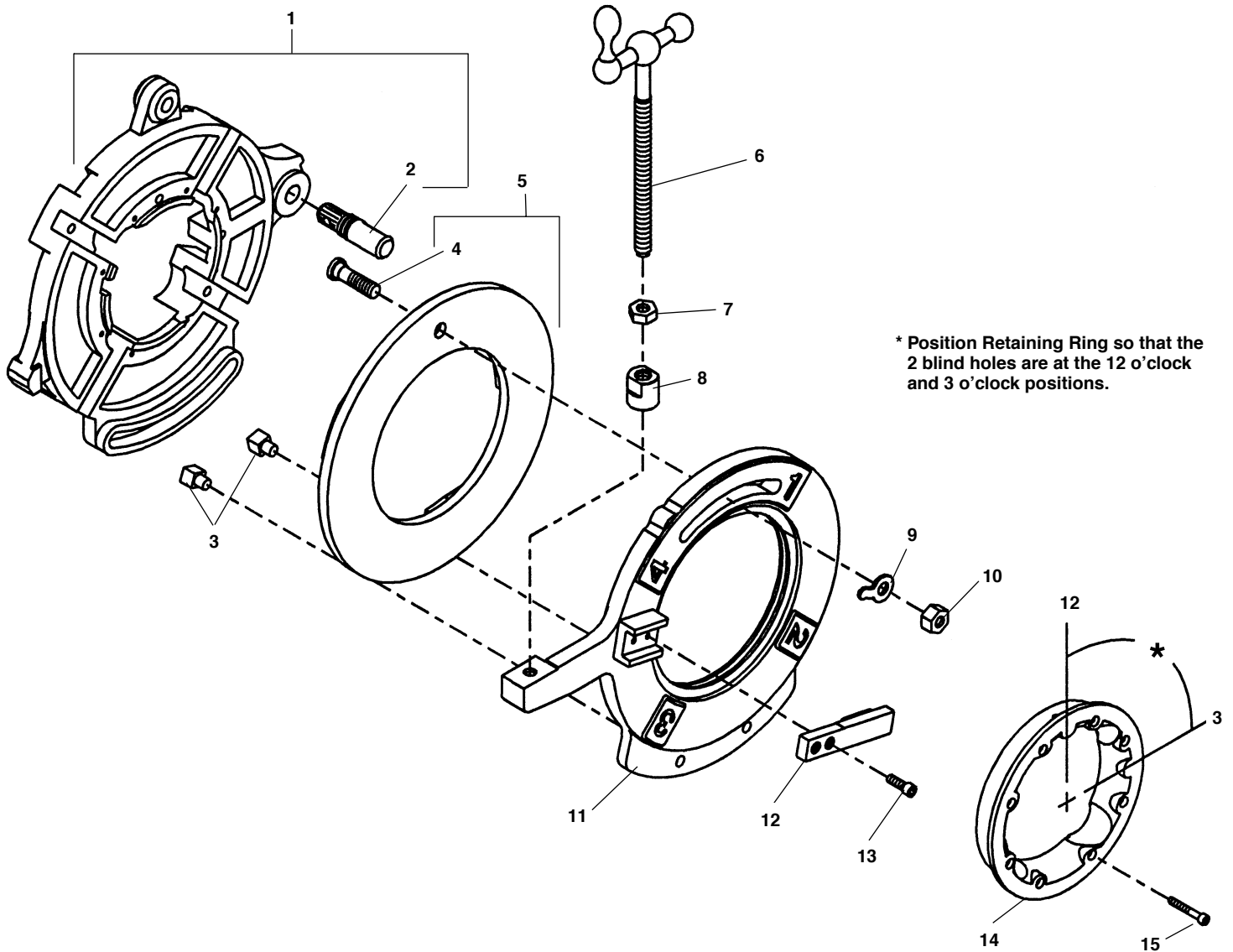

* Position Retaining Ring so that the 2 blind holes are at the 12 o'clock and 3 o'clock positions.

**NOTE: Order parts by Catalog Number only.
DO NOT order by Reference Number.**

Ref. No.	Catalog No.	Description
—	55447	725 Grooving Die Head
1	58687	Die Head With Post
2	59827	Die Head post
3	26632	Drive Block
4	26952	Cam Assembly
5	33227	Cam Bolt
6	58692	Feed Screw Assembly
7	44745	Jam Nut
8	58697	Adjusting Nut
9	26957	Lever Washer
10	26887	Hex Nut 7/16" - 20
11	58702	Cam Locking Plate
12	58707	Stop
13	40910	Screw #1/2 - 20 x 3/4" (2)
14	26637	Retaining Ring
15	26642	Screw #10 - 32 x 1 3/8" (8)

“ML” Oil Pump

NOTE: Order parts by Catalog Number only.
DO NOT order by Reference Number.

Ref. No.	Catalog No.	Description
—†	27307	“ML” Oil Pump
1	33442	Pump Valve Body
2	33432	Compression Fitting (2)
3*	33457	Gasket (Set of 2)
4*	33452	Valve Retainer Assy.
5	33482	Gerotor Housing w/Bearing
6*	33477	O-Ring
7†	33462	Sleeve Bearing
8	33467	Gerotor Set
9	33447	Pump Cap w/Seal
10*	33472	Oil Seal
11	44510	Soc. Hd. Cap Screw 1/4" - 20 x 2"
12	45150	Lock Washer 1/4"
*	33422	“ML” Service Kit

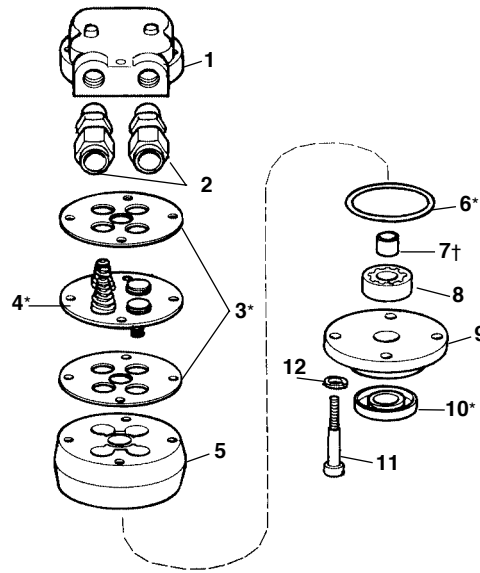

Note: Ref. 7 Sleeve Bearing used on older Gerotor Housings, not required on new pumps.

* Indicates Part is Included in Service Kit.

† See Service Note

No. 764 Pipe Cutter

Ref. No.	Catalog No.	Description
—	26212	764 Pipe Cutter
1	26752	Screw Handle
2	41730	Ball Bearing
3	26742	Cutter Frame
4	26747	Roll Housing
5	26757	Groove Pin
6	26762	Groove Pin (2)
7	33125	Cutter Wheel
8	34785	Roll (2)
9	26252	Roll F/Coated Pipe (2 per set)
10	34790	Wheel Pin
11	27072	Groove Pin

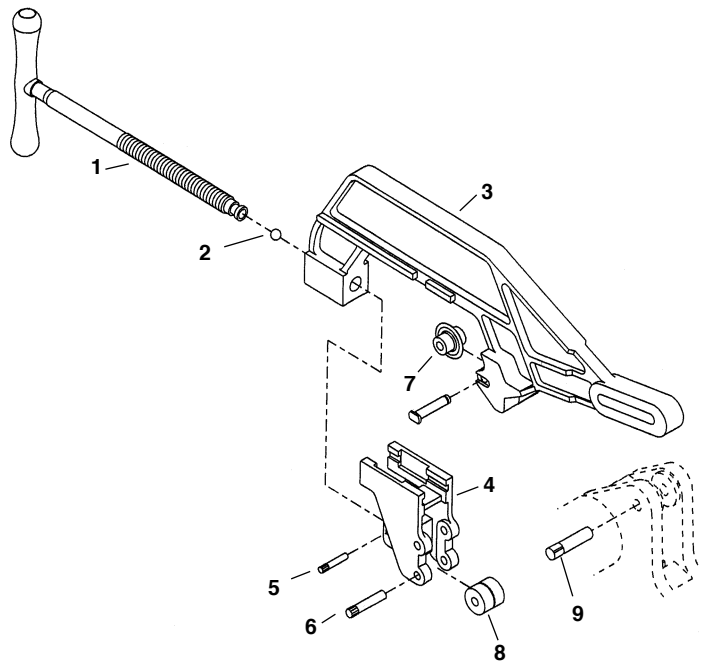

No. 744 Reamer Assembly

Ref. No.	Catalog No.	Description
—	26217	744 Reamer Assembly
1	26602	Reamer Arm
2	34577	Reamer Blade 1/4" - 4"
3	27037	Shoulder Bolt
4	27072	Groove Pin
5	26607	Pivot Block
6	26727	Groove Pin (2)

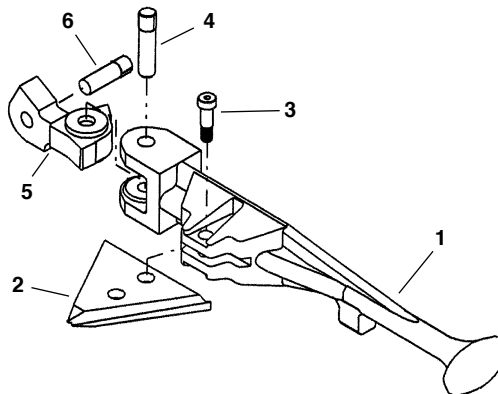

No. 766 Saran Cut-Off Tool

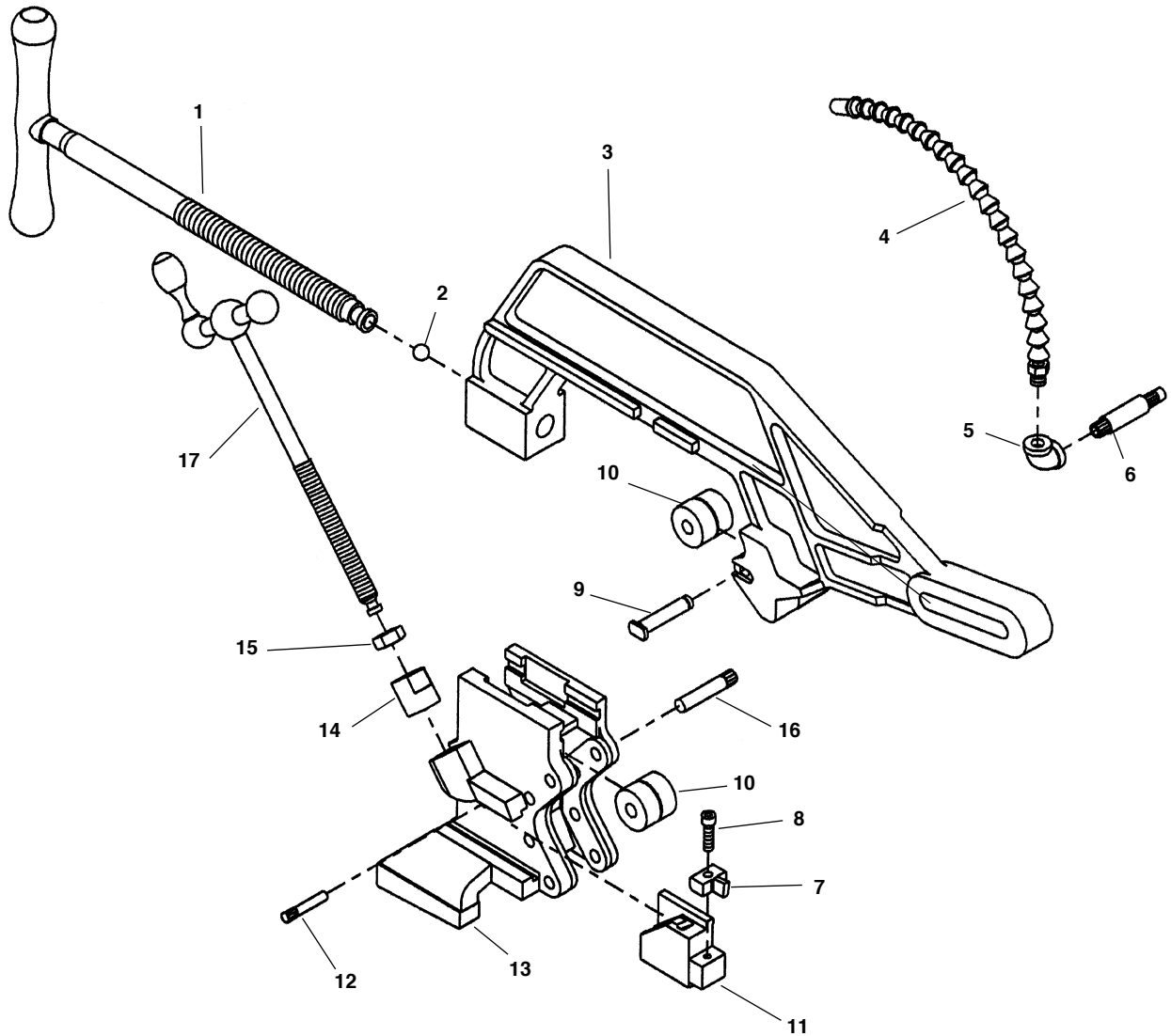

**NOTE: Order parts by Catalog Number only.
DO NOT order by Reference Number.**

Ref. No.	Catalog No.	Description
—	55452	766 Saran Cut-Off Tool
1	26752	Feed Screw Handle
2	41730	Steel Ball
3	26742	Cutter Frame
4	39845	Coolant Nozzle
5	39855	90° Elbow
6	57522	Carriage Bypass Pin
7	58712	Tool Bit
8	27357	Screw 1/4" - 20 x 7/8"
9	56932	Pin
10	34785	Rolls (5)
11	58717	Tool Holder Slide
12	26757	Groove Pin
13	58722	Roll Housing
14	58697	Adjustment Nut
15	44745	Jam Nut
16	26762	Groove Pin (4)
17	40027	Feed Screw Assembly
—	46190	1/4" Hex Key
—	49737	Lockout Plate F/Die Head

60 Hz Electrical Components

NOTE: Order parts by Catalog Number only. DO NOT order by Reference Number.

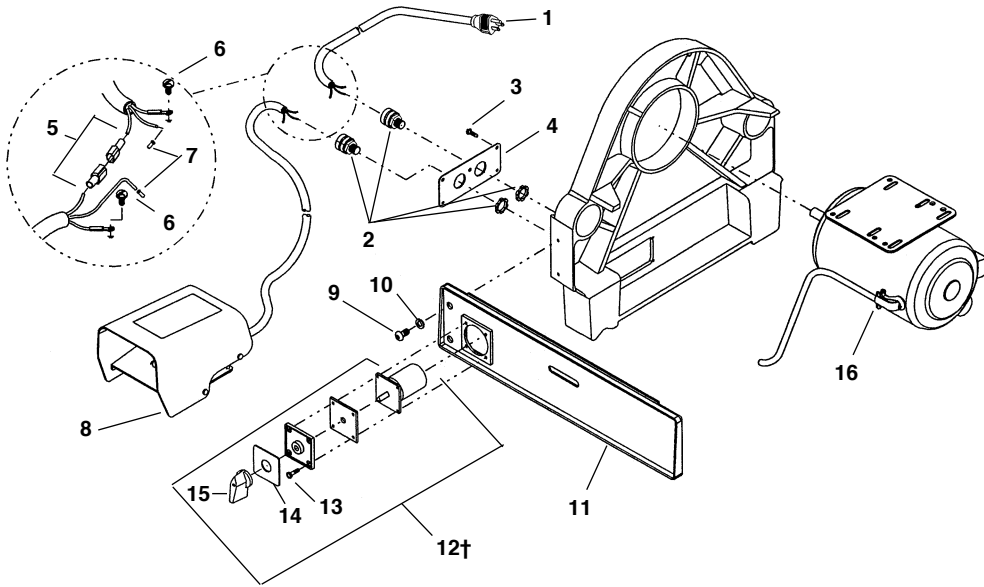

Ref. No.	Catalog No.	Description
1	46740	Power Cord
	46410	Power Cord
2	68885	Strain Relief (2)
3	41597	Self Tapping Screw (4)
4	27162	Strain Relief Bracket
5	56407	Quick Disconnect Set
6	45420	Ground Screw
7	36222	Wire Terminal
8	36642	B-294 Foot Switch
9	26997	Screw 3/8" - 16 x 3/4" (8)
10	40930	Lock Washer 3/8" (8)
11	59722	Front Side Plate
12†	59757	Switch Assembly
13	59727	Switch Screws (4)
14	59712	Switch Plate
15	59702	Switch Knob
16	26237	Motor 120V 60 Hz
	26232	Motor 240V 60 Hz

1224 & 1822-I Replacement Switch Wiring Diagram

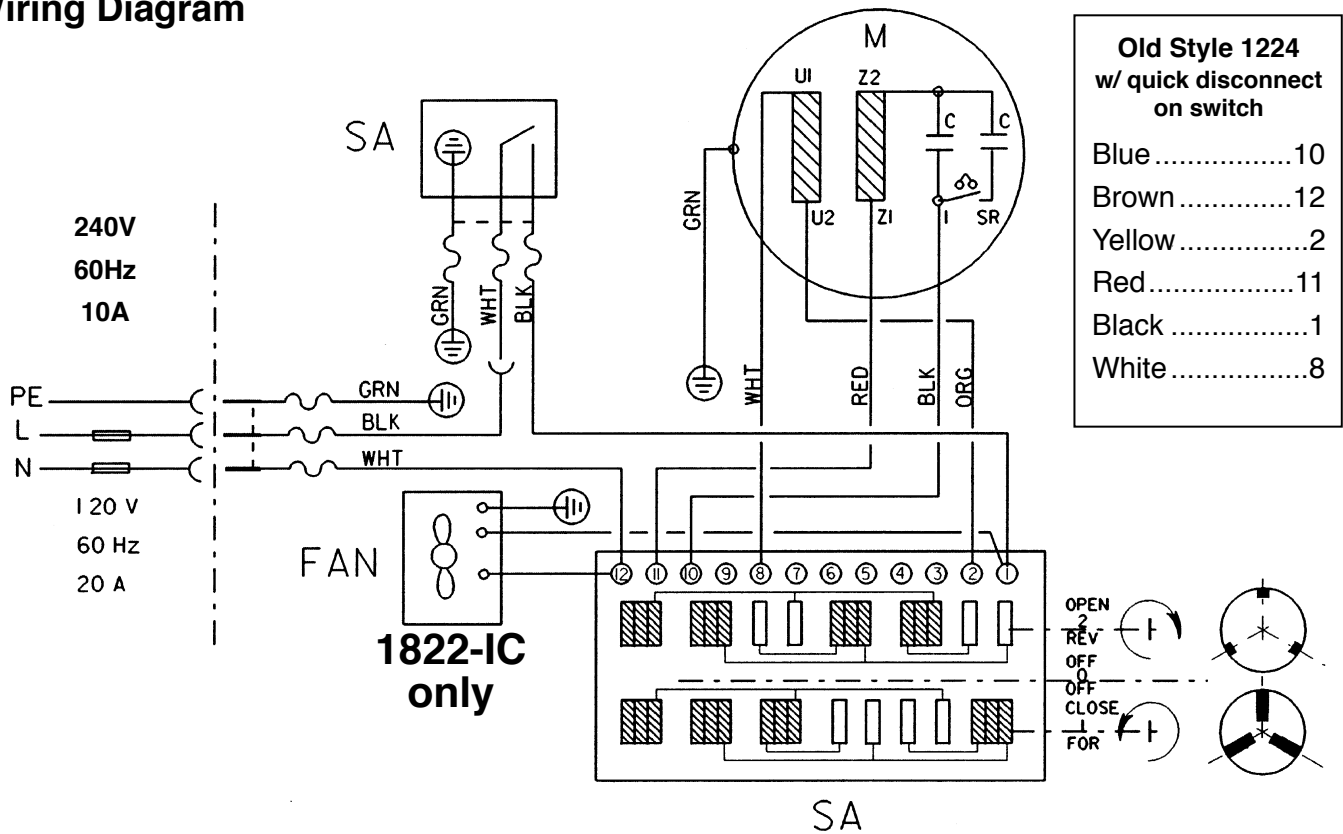

Old Style 1224 w/ quick disconnect on switch	
Blue	10
Brown	12
Yellow	2
Red	11
Black	1
White	8

50 Hz Electrical Components

NOTE: Order parts by Catalog Number only. DO NOT order by Reference Number.

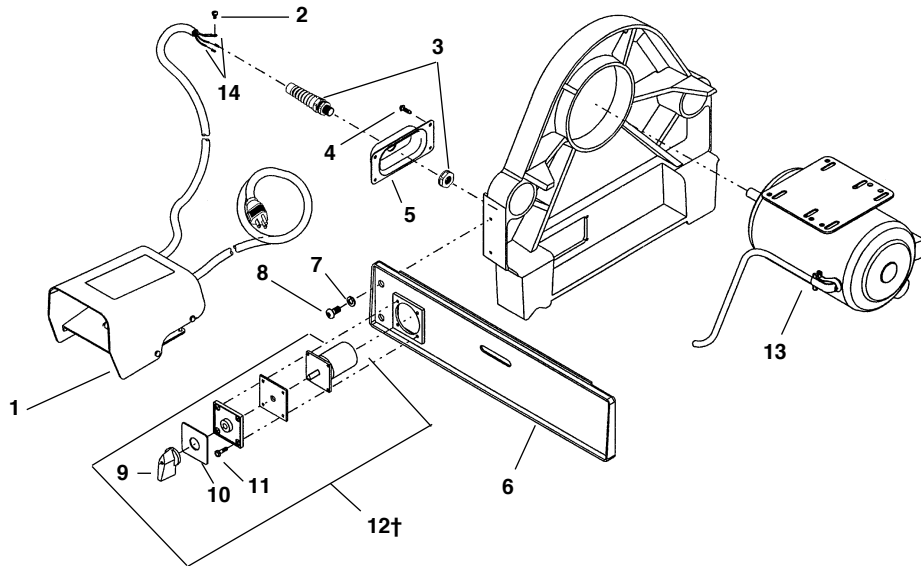

Ref. No.	Catalog No.	Description
1	36652	B-296 Foot Switch
	36657	B-297 Foot Switch
2	45420	Ground Screw
3	27187	Strain Relief
4	41597	Self Tapping Screw (4)
5	27197	Strain Relief Bracket
6	59722	Front Side Plate
7	40930	Lock Washer 3/8" (8)
8	26997	Screw 3/8" - 16 x 3/4" (8)
9	59702	Switch Knob
10	59717	Switch Plate
11	45280	Switch Screws (4)
12†	59757	Switch Assembly
13	27282	Motor 220/240V 50 Hz
	27287	Motor 110V 50 Hz
14		Wire Terminal

† Ref. No. 12 – When replacing early style switches, which have a black body, order Switch Kit, Catalog No. 59762. Kit includes 59757 Switch Assembly and 59742 Switch Adapter Plate

1224 & 1822-I Replacement Switch Wiring Diagram

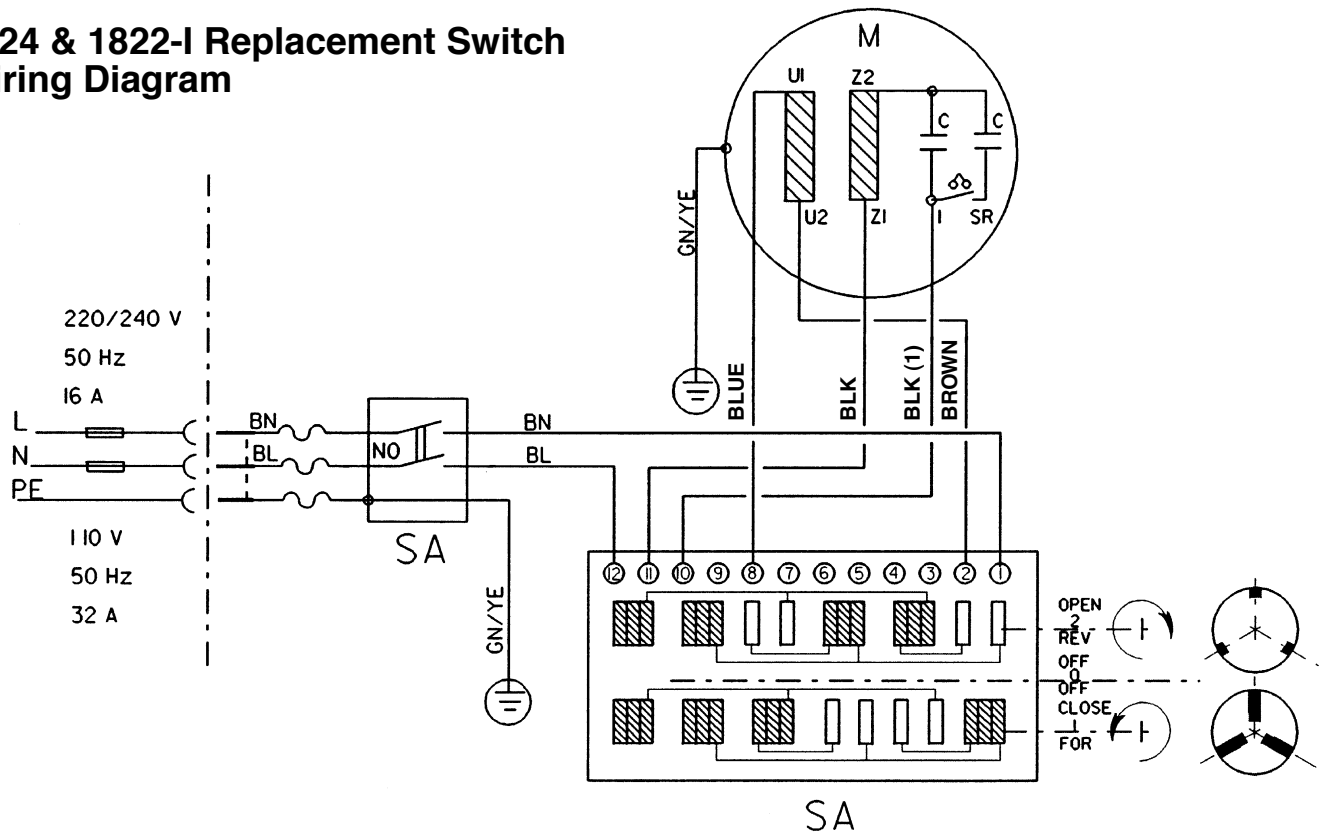

Gear Box

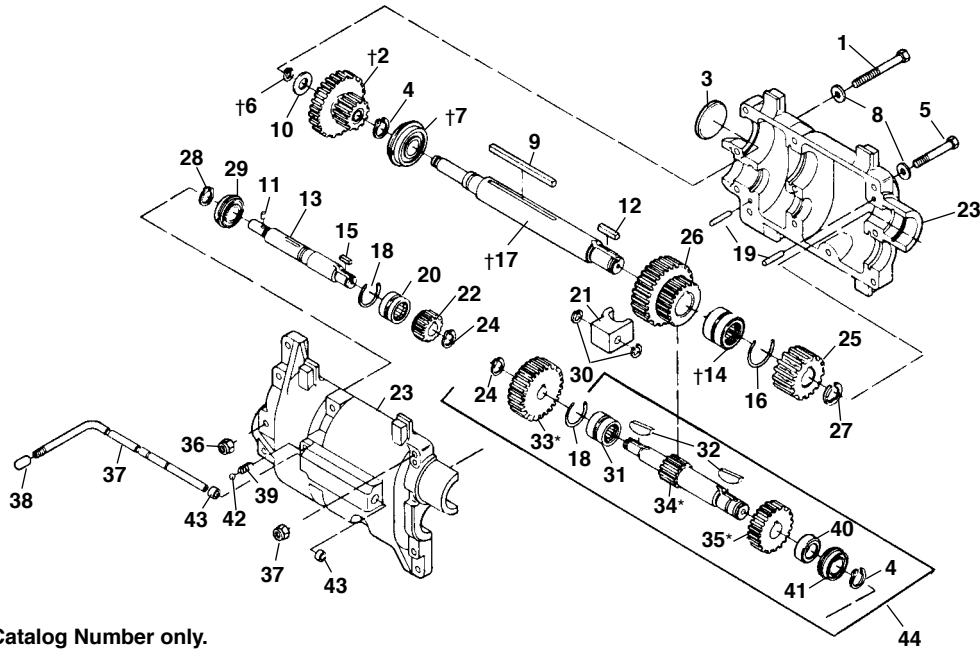

**NOTE: Order parts by Catalog Number only.
DO NOT order by Reference Number.**

Ref. No.	Catalog No.	Description	Ref. No.	Catalog No.	Description	Ref. No.	Catalog No.	Description
—	26362	Gear Box Assembly	16	26922	Wire Ring	32	33982	Woodruff Key (2)
1	27102	Screw 5/16" - 18 x 3 1/4" (2)	†17	26382	Output Shaft	33*	33992	1st Gear Constant Speed
†2	26702	Fixed Gear Cluster Assembly	18	26917	Wire Ring (2)	34*	33987	Constant Speed Shaft
3	26667	Freeze Plug	19	26662	Dowel Pin (2)	†35*	33997	Large Constant Speed Gear
4	26412	Snap Ring (2)	20	26367	Front Input Bearing	36	75110	Stop Nut 5/16" - 18 (11)
5	27107	Screw 5/16" - 18 x 2 1/2" (9)	21	26437	Shifting Fork	37	26442	Shift Slide
†6	27117	Snap Ring	22	26377	1st Input Gear	38	27032	Shifter Knob
†7	26417	Rear Output Bearing	23	26647	Gear Box	39	26692	Shifter Detente Spring
8	96740	Washer 5/16" (11)	24	26677	Snap Ring	40	26452	Spacer
9	26552	Shift Cluster Key	†25	26432	Output Pinion Gear	41	26407	Front Constant Speed Bearing
10	26672	Thrust Washer	26	26422	Cluster Shift Gear	42	46925	Steel Ball
11	26907	Spiral Pin	27	26557	Snap Ring	43	26447	Shift Slide Sleeve Bearing
12	26457	Output Pinion Key	28	44430	Retaining Ring	26707	26707	Grease (1 lb. can)
13	26902	Input Shaft Assembly	†29	26372	Input Rear Bearing	44	28047	Constant Speed Assembly
†14	26427	Front Output Bearing	30	34245	Rings Set of 5			
15	26657	Input Pinion Key	31	26397	Rear Bearing			

†See Service Notes

*When replacing early style parts, using square keys, a complete shaft assembly (Ref. No. 44) should be used.

**Nos. 541, 542, 713 & 913
Quick-Opening
Die Heads**

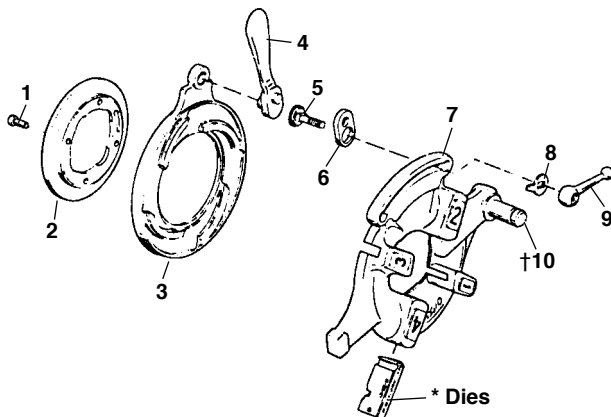

Ref. No.	Catalog No.	Description
—	26162	541 Quick-Opening Bolt Die Head 1/4" - 1"
—	26167	542 Quick-Opening Bolt Die Head 1 1/8" - 2"
—	26142	713 Quick-Opening Die Head (NPT) 1/4" - 2"
—	26147	913 Quick-Opening Die Head (BSPT) 1/4" - 2"
1	32205	Screw 1/4" - 20 x 5/8" (4)
2	23292	Retaining Ring L.H. (713, 913)
	46620	Retaining Ring (541)
	46625	Retaining Ring (542)
3	43360	Cam Plate L.H. (713, 913)
	43405	Cam Plate (541)
	43410	Cam Plate (542)
4	46520	Throw-out Lever (713, 913)
	46555	Throw-out Lever (541, 542)
5	39860	Lock Screw (713, 913)
	39955	Lock Screw (541, 542)
6	39950	Link
7	26897	Head w/Post & Latch Assembly (913)
	26982	Head w/Post (541)
	26987	Head w/Post (542)
	27267	Head w/Post & Latch Assembly (713)
8	39460	Lever Washer
9	39970	Clamp Lever
†10	59827	Post

† - See Service Notes

**Service Notes
Transmission**

Position Bearing (Ref. No. 29) with O.D. Snap Ring towards shoulder of Input Shaft.

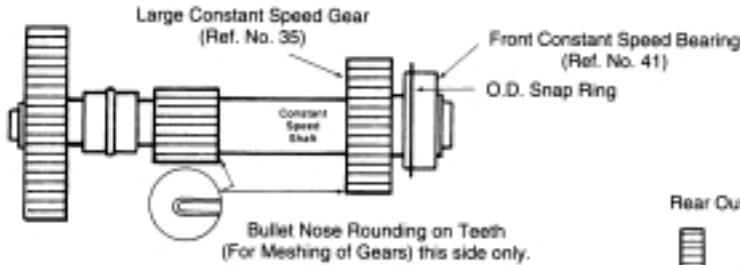
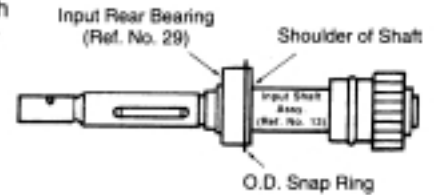

Position Large Constant Speed Gear Ref. No. 35 so that bullet nose side of gear teeth are facing toward center of shaft.
Position O.D. Snap Ring towards Large Constant Speed Gear.

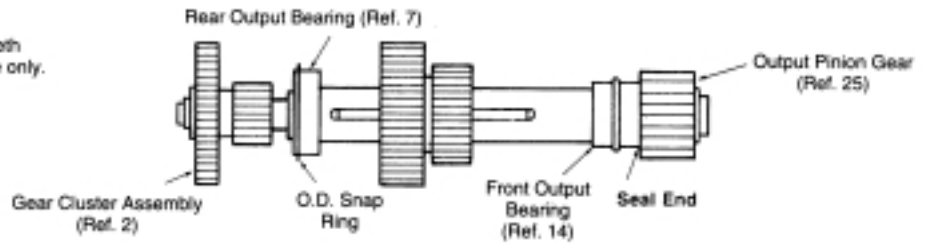

Position Bearing (Ref. No. 7) with O.D. Snap Ring towards Gear Cluster (Ref. No. 2)

Position Seal End of Front Output Bearing (Ref. No. 14) towards Output Pinion Gear (Ref. No. 25)

Replacement Instructions for Die Head Post

All 1224 Die Heads— 541, 542, 711, 713, 714, 911, 913, 914

—IMPORTANT—

Post must be properly oriented to insure oil flow through head. Insert illustrates proper relationship (parallel) of "flat" on die head post to flat "machined surface" of die head casting.

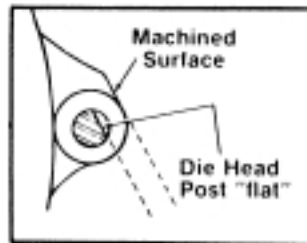

Oil Pump

Installing Oil Pump Onto Input Shaft Assembly

1. Align Square Slot (behind seal) in the No. 27307 Oil Pump with the Drive Pin in the No. 26902 Gear Box Input Shaft Assembly.
2. Slide Oil Pump onto Input Shaft Assembly.
3. When Pump is properly engaged onto Shaft, the distance between Pump body and Keyway Slot should not exceed 1/8 inch.

