

No. 150 and 150L

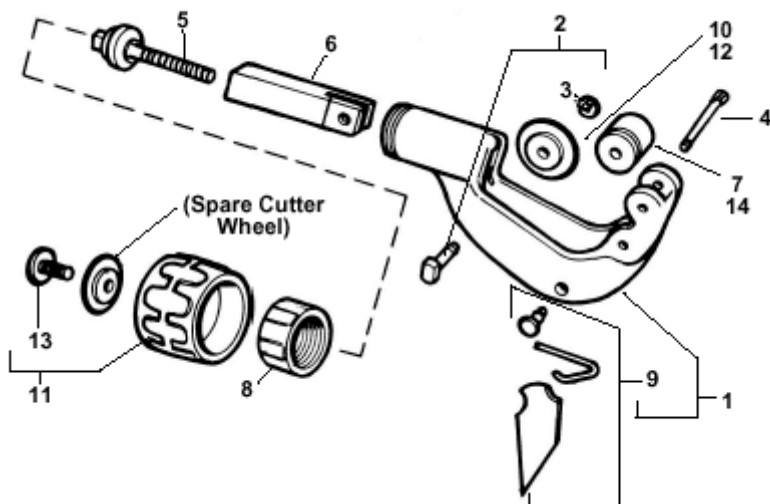

Ref. No.	Description	No. 150	No. 150L
		Catalog No.	Catalog No.
1	Frame Assembly	33127	92747
2	Pin and Clip	33800	33800
3	Clip	74740	74740
4	Roll Pin (2)	33142	33142
5	Feed Screw	33132	92742
6	Slide Bar	33137	92737
7	Roll (2)	34640	34640
8	Bearing Cap	34645	34645
9	Reamer Blade Kit	34650	34650
10	Cutter Wheel (Thin)	33185	33185
11	Knob Assembly	33177	33177
12	Cutter Wheel (H. Duty)	33190	33190
13	Screw	34750	34750
14	Solid Roll (Special)	34765	34765

Nos. 205 and 205-P (Plastic)

Capacity: 1/4" through 2 3/8"

**NOTE: Order parts by Catalog Number only.
DO NOT order by Reference Number.**

Ref. No.	Catalog No.	Description
1	33395	Frame Assembly
2	33805	Pin and Clip
3	74740	Clip
4	34625	Knob Assembly
5	34650	Reamer Blade Assembly
6	34660	Feed Screw Assembly
7	34665	Small Roll (2)
8	34670	Large Roll (2)
9	32112	Roll Pin (4)
10	34680	Latch Assembly
11	34685	Latch Spring
12	34690	Latch Pin
13	34700	Slide Bar Assembly
14	34705	Ratchet Shaft
15	34750	Screw with Washer
16	34720	Pin
17	34725	Bearing Cap
18	34730	Feed Screw Nut
19	34745	Snap Ring

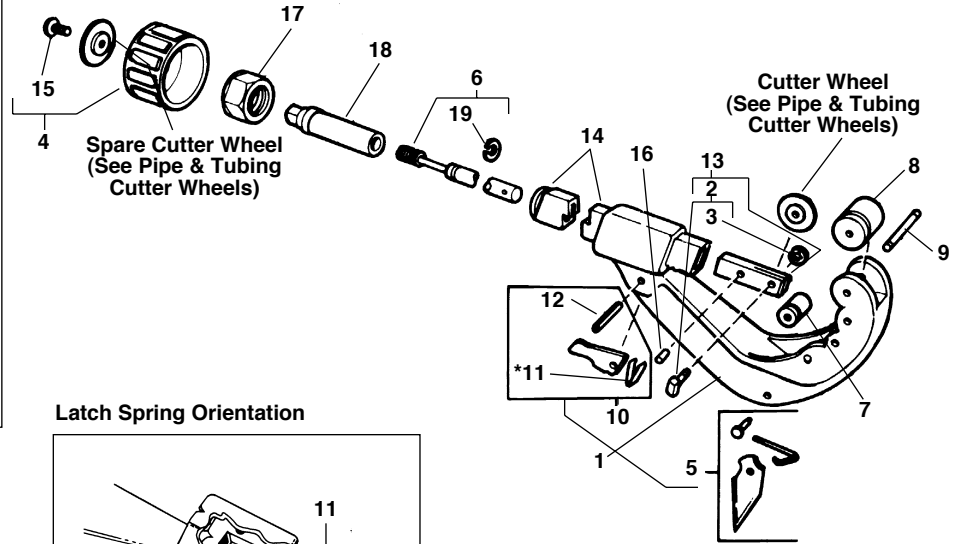

**Note: Earlier Cutter used 34735
Wheel Screw and 45175 Washer.
Update by using 34700**

No. 50 Muffler Cutter

Capacity: 1/8" through 2 1/2" O.D.

Ref. No.	Catalog No.	Description
1	42372	Frame Assembly
2	42382	Screw Handle
3	42377	Roll Housing
4	39537	Roll Pin (2)
5	34775	Roll (2)
6	34780	Wheel Pin
7	41852	Cutter Wheel

