

**NOTE: Order parts by Catalog Number only.
DO NOT order by Reference Number.**

Ref. No.	Catalog No.	Description
†1	43033	Feedscrew
2	43038	Knob
3	43163	Retaining Ring
4	43058	Nosepiece
5	43053	Split Washer
6	43043	Thrust Washer
†7	43048	Bronze Washer
8	43063	Side Handle
9	43023	Outer Cylinder
†10	43078	5/8"-18 x 1" Set Screw
†11	60802	Jam Nut 5/8"-18
12	43073	Warning Label
13	33680	Pin
†14	43028	Inner Nut
15	33220	Cutter Wheel
16	43068	Chain Assembly
17	33675	Chain Ring
18	94760	Retaining Ring
19	33605	Hook Assembly
-	70437	1/2" Ratchet (Not Shown)

† Service Note: Ref. Nos. 1, 7 and 14 coat with EP grease.

† When replacing Ref. Nos. 10 and 11 apply Loctite® RC 680 to each part. When tightening Ref. No. 10, screw down until bottoming out on Inner Nut. Then back-off so Inner Nut (Ref. No. 14) slides freely. Then tighten Jam Nut (Ref. No. 11).

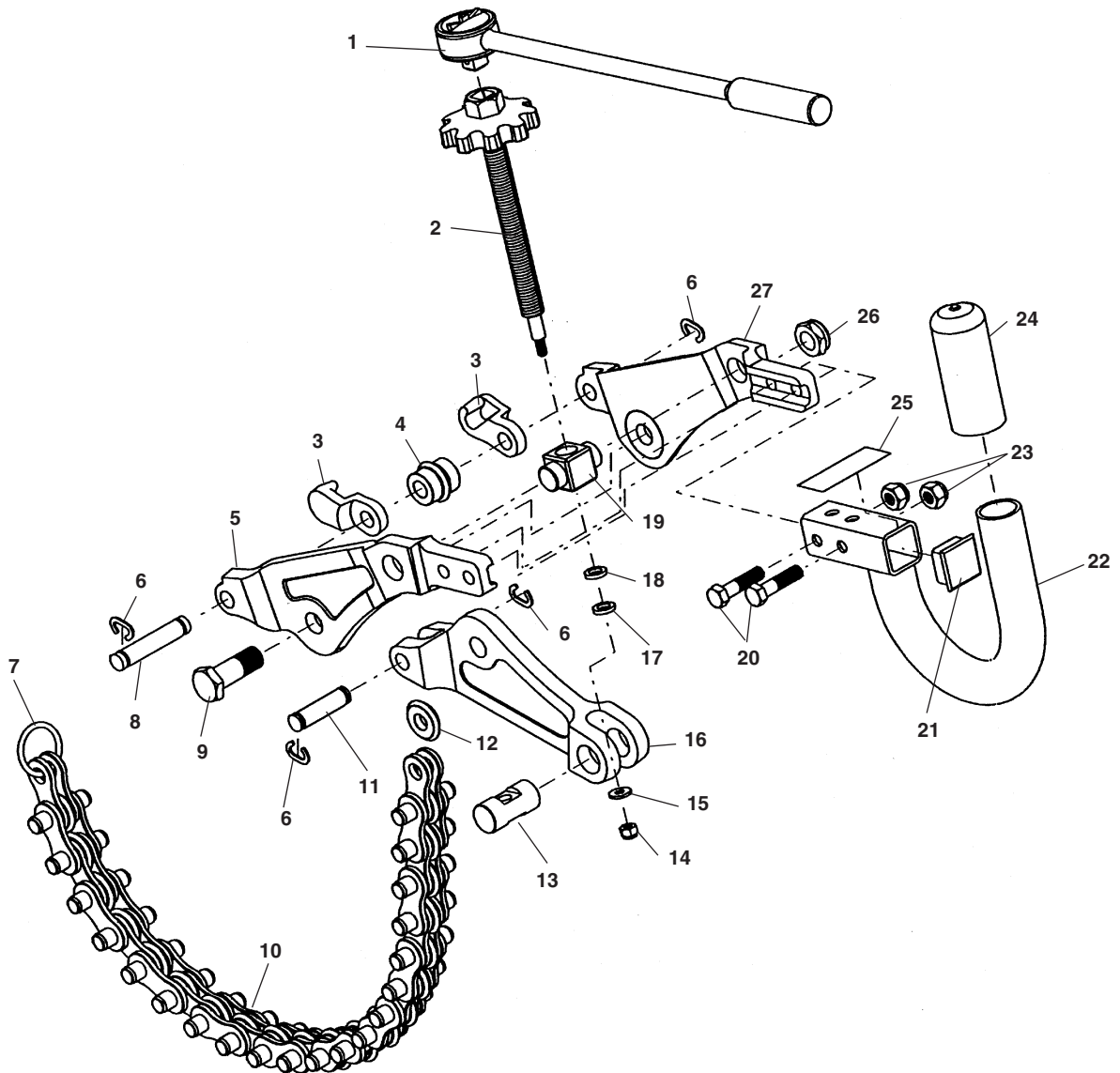

**NOTE: Order parts by Catalog Number only.
DO NOT order by Reference Number.**

Ref. No.	Catalog No.	Description	Ref. No.	Catalog No.	Description
—	69982	226 Soil Pipe Cutter Assembly	14	83890	Nut 1/4" - 20
1	70437	Ratchet	15	27402	Flat Washer 1/4" I.D.
2	71772	Feed Screw w/Knob	16	71812	Center Arm
3	33605	Hook Assembly	17	71782	Bronze Thrust Washer
4	33635	Spacer Wheel	18	71777	Steel Thrust Washer
5	71797	Left Arm	19	71792	Pivot Nut
6	33685	Retaining Ring (4)	20	83120	Hex Screw 3/8" x 16 x 1 3/4" (2)
7	33675	Chain Ring	21	71822	Plug 1.25" SQ.
8	33650	Pin	22	71817	Handle
9	44312	Hex Head Screw 5/8" - 18 x 1 3/4"	23	79985	Stop Nut 3/8" - 16 (2)
10	33670	Chain Assembly	24	71832	Handle Grip
11	33645	Pin	25	72032	Warning Label
12	33220	Cutter Wheel	26	71827	Nut 5/8" - 18
13	71807	Pivot Pin	27	71787	Right Arm

Официальный дистрибьютор в России с 1996 года (921) 936-02-07, (812) 331-37-51

No-Hub® Soil Pipe
Capacity: 2" – 6"

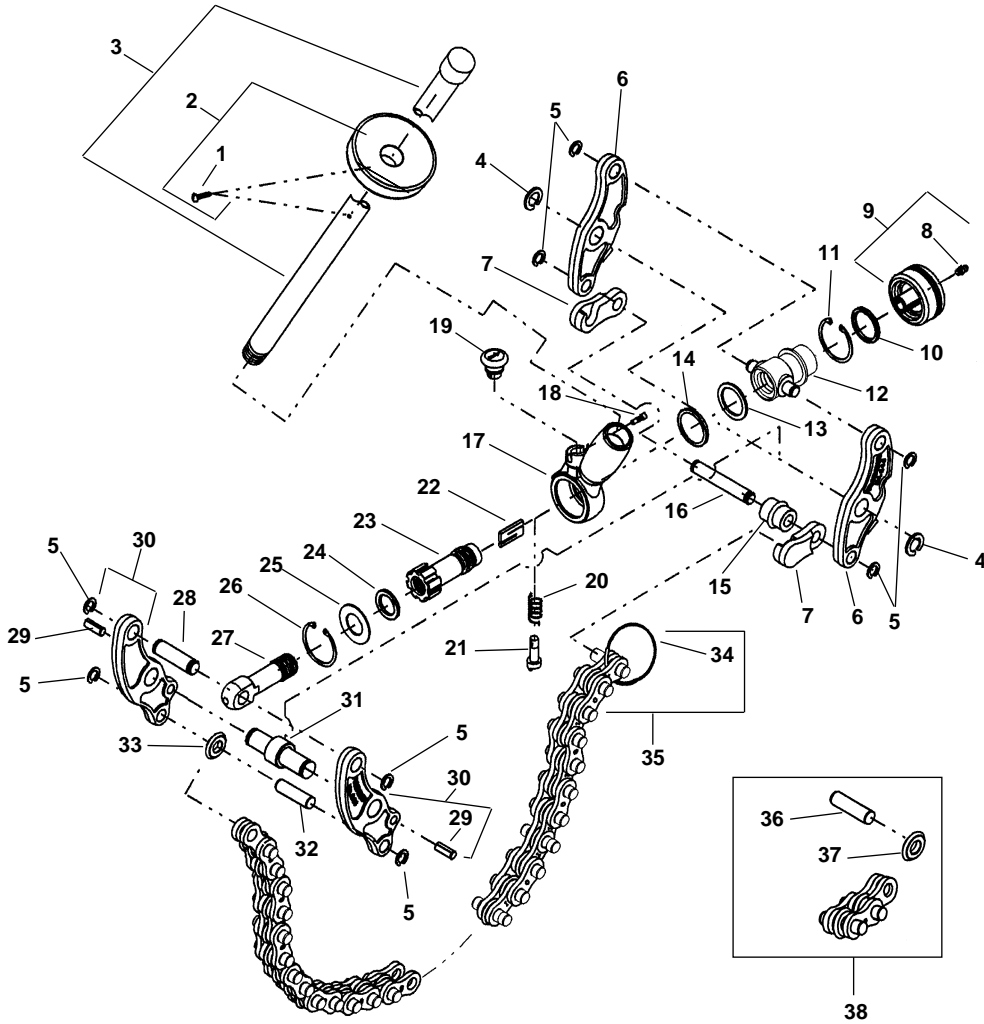

**NOTE: Order parts by Catalog Number only.
DO NOT order by Reference Number.**

Ref. Catalog No.	No.	Description	Ref. Catalog No.	No.	Description	Ref. Catalog No.	No.	Description
-	68650	206 Soil Pipe Cutter	13	33715	Seal	26	33695	Retaining Ring
1	46470	Set Screw	14	33625	Cup	27	33615	Eyebolt
2	33440	Handle Stop Assembly	15	33635	Spacer Wheel Assy. (Incl Ref. 5)	28	33730	Pin
3	33740	Handle Assembly	16	33650	Pin	29	51502	Spiral Pin
4	33690	Retaining Ring (2)	17	33425	Ratchet Assembly (Incl. Ref. 18-21)	30	34187	Side Arm (Inside) (2)
5	33685	Retaining Ring (8)	18	38705	Pawl Pin	31	33640	Center Pin Assembly
6	34192	Side Arm Outside (2)	19	38700	Ratchet Knob	32	33645	Pin
7	33605	Hook Assembly	20	33725	Pawl Spring	33	33630	Cutter Wheel Assembly (Incl. Ref 5)
8	46860	Grease Fitting	21	38690	Ratchet Pawl	34	33675	Ring
9	33595	Knob Assembly	22	33770	Drive Blade	35	33670	Chain Assembly
10	33710	Seal	23	33435	Ratchet Shaft Assembly	36	33680	Cutter Pin
11	33700	Retaining Ring	24	33705	Seal	37	33220	Cutter Wheel
12	33430	Trunnion	25	33620	Washer	38	33665	Chain Extension Assembly

* **33665 CHAIN EXTENSION ASSEMBLY** – Includes 33220 Cutter Wheels (2), 33655 Inside Links (2), 336601 Outside Links (2) and 33680 Cutter Pins (2) per section. Each section is approximately 3 inches long.

* **33665 CHAIN EXTENSION ASSEMBLY** is completely assembled, except for one cutter wheel and one pin, packed loose. These are needed to make the connection on the existing chain. Each section is approximately 3 inches long. Remove the 33675 Ring at the end of the existing chain...connect the loose wheel and pin to the inner link on the chain. Attach the 33675 Ring to the end of the chain extension.

WARNING: Do not cut soil pipe larger diameter than: Clay - 12" diameter; Cast Iron - 8" diameter

Официальный дистрибьютор в России с 1996 года (921) 936-02-07, (812) 331-37-51

RIDGID No. 246 Soil Pipe Cutter

Soil Pipe Capacity: 2" – 6"

Water Main Capacity: Class 22, 4"

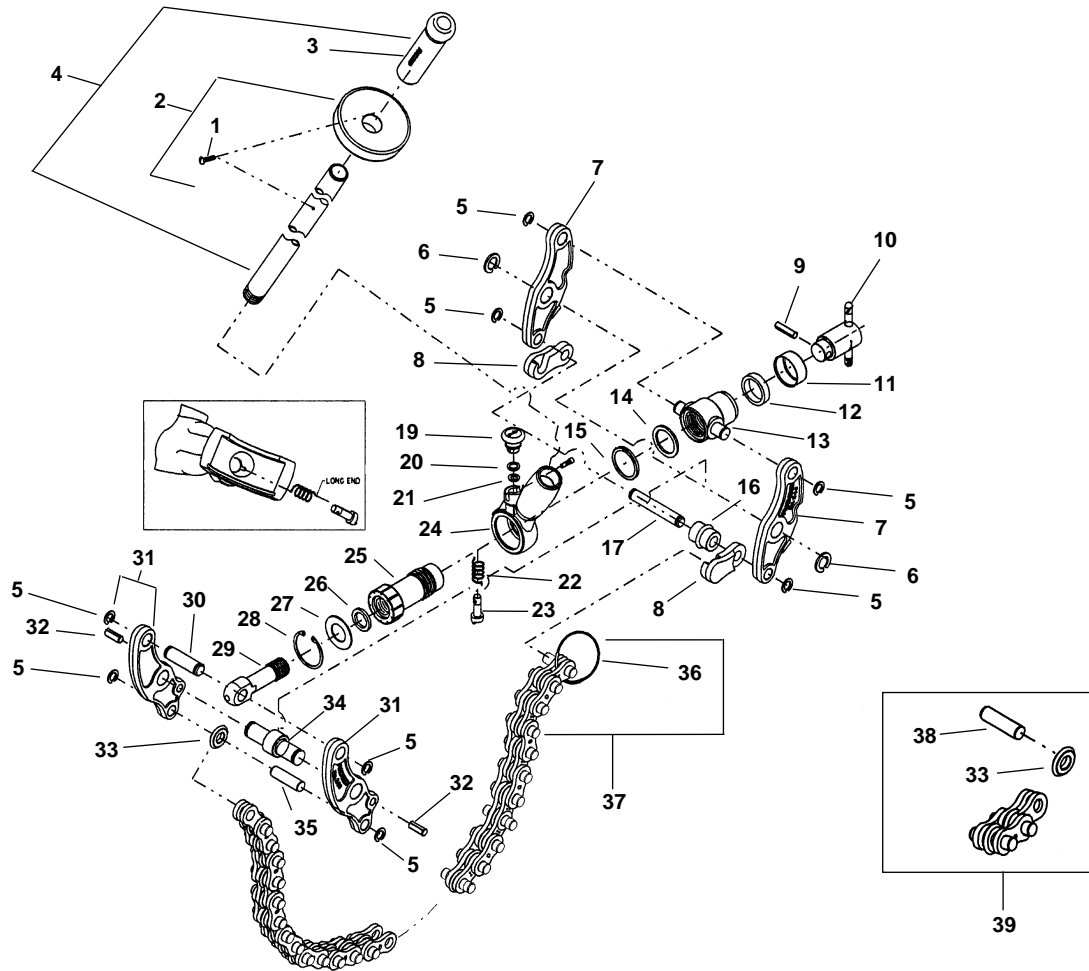

**NOTE: Order parts by Catalog Number only.
DO NOT order by Reference Number.**

Ref. No.	Catalog No.	Description	Ref. No.	Catalog No.	Description	Ref. No.	Catalog No.	Description
-	32900	246 Soil Pipe Cutter	14	34500	Seal	27	34520	Ratchet Housing Washer
1	46470	Screw	15	34490	Cup	28	33700	Retaining Ring
2	33795	Handle Stop Assembly	16	34440	Spacer Wheel	29	34480	Eyebolt
3	51630	Handgrip	17	34460	Spacer Pin	30	34455	Eyebolt Pin
4	34545	Handle Assembly	18	34450	Pawl Pin	31	33560	Slide Bar (Inside) (2)
5	34550	Retaining Ring (8)	19	38700	Ratchet Knob	32	51502	Spiral Pin (2)
6	34555	Retaining Ring (2)	20	34495	Seal	34	34445	Center Pin
7	33550	Side Bar (Outside) (2)	21	34485	Cup	35	34465	Chain Pin
8	33790	Hook Assembly	22	34525	Ratchet Pawl Spring	36	33675	Ring
9	34565	Spring Pin	23	34475	Ratchet Pawl	37	34575	Chain Assembly
10	33555	Knob and Handle Assembly	24	99530	Ratchet Housing Assembly	38	34470	Cutter, Wheel Pin
11	34515	Cup	25	99520	Ratchet Shaft	33	33225	Cutter Wheel
12	34510	Seal	26	34505	Eyebolt Seal	39	34570	Chain Extension Assembly
13	99525	Trunnion						

* 34570 CHAIN EXTENSION ASSEMBLY—Includes 33225 Cutter Wheels (2), 34535 Inside Links (2), 34540 Outside Links (2) and 34470 Cutter Pins (2) per section. 34570 CHAIN EXTENSION ASSEMBLY is completely assembled, except for one cutter wheel and one pin, packed loose. These are needed to make the connection to the existing chain. Each section is approximately 3 inches long. Remove the 33675 Ring at the end of the existing chain...connect the loose wheel and pin to the inner link on the chain. Attach the 33675 Ring to the end of the chain extension.

WARNING: Do not cut soil pipe larger diameter than: Clay – 12" diameter; Cast Iron – 8" diameter

Официальный дистрибьютор в России с 1996 года (921) 936-02-07, (812) 331-37-51

Ridge Tool Company/Elyria, Ohio, U.S.A.

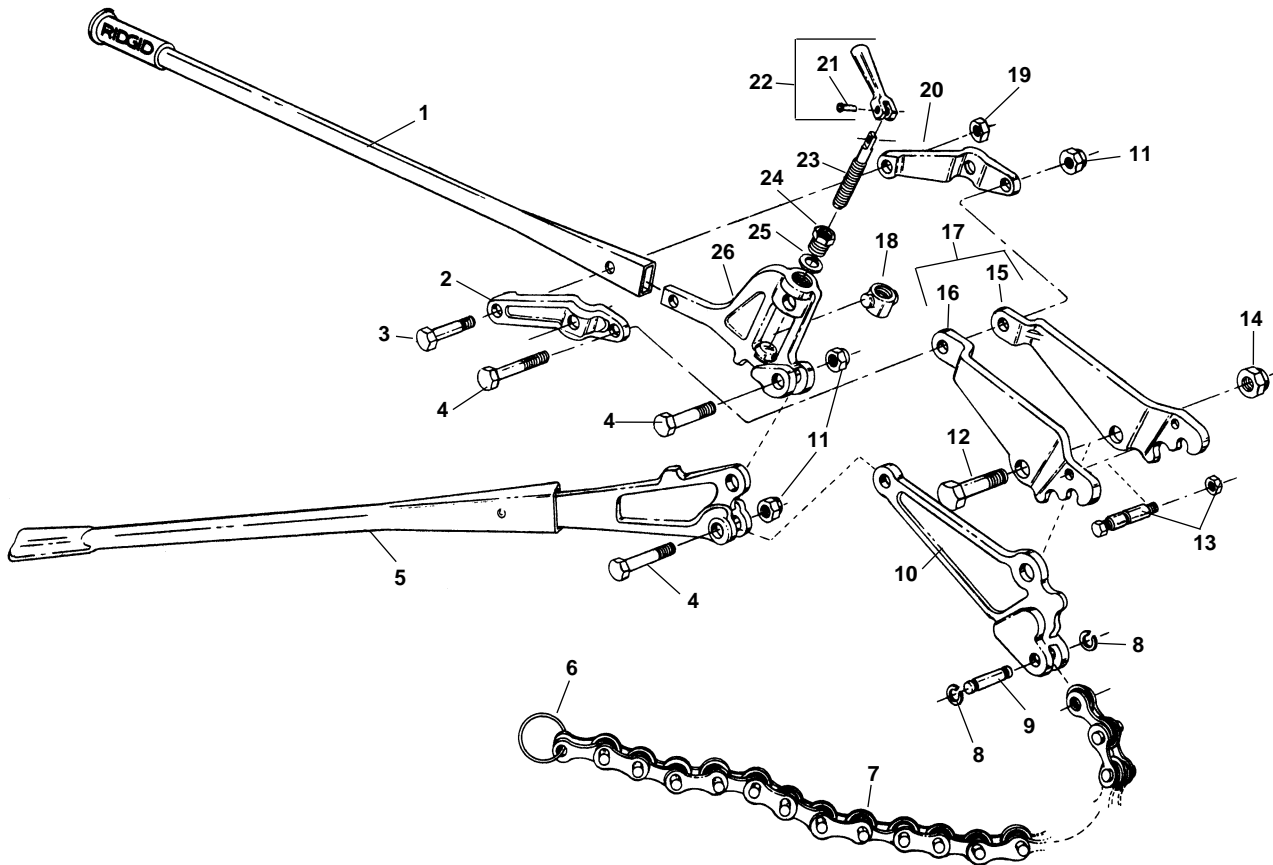

**NOTE: Order parts by Catalog Number only.
DO NOT order by Reference Number.**

Ref. No.	Catalog No.	Description	Ref. No.	Catalog No.	Description
—	43547	266 Soil Pipe Cutter	13	74082	Spacer Bolt Assembly – 276
—	74207	276 Soil Pipe Cutter	14	44322	Locking Nut
1	44247	Left Handle	15	44627	Right Jaw – 266
2	44262	Left Handle Bracket		74092	Right Jaw – 276
3	44302	Shoulder Bolt	16	44622	Left Jaw – 266
4	44307	Shoulder Bolt (3)		74097	Left Jaw – 276
5	44242	Right Handle	17	44297	Top Jaw Assembly – 266
6	33675	Ring	18	44267	Adjusting Block
7	34575	Chain Assembly – 266	19	46820	Hex Nut
	33670	Chain Assembly – 276	20	44257	Right Handle Bracket
8	34550	E-2655 Retaining Ring (2)	†21	44332	Rivet
9	34465	Chain Pin	22	44277	Adjusting Screw Handle w/Rivet
10	44292	Bottom Jaw – 266	23	44272	Adjusting Screw
	74087	Bottom Jaw – 276	24	44282	Adjusting Screw Locknut
11	44317	Locking Nut (3)	26	44327	Washer
12	44312	Shoulder Bolt	26	44252	Adjusting Screw Housing
13	44287	Spacer Bolt Assembly – 266			

Официальный дистрибьютор в России с 1996 года (921) 936-02-07, (812) 331-37-51

Capacity: 2" through 8"

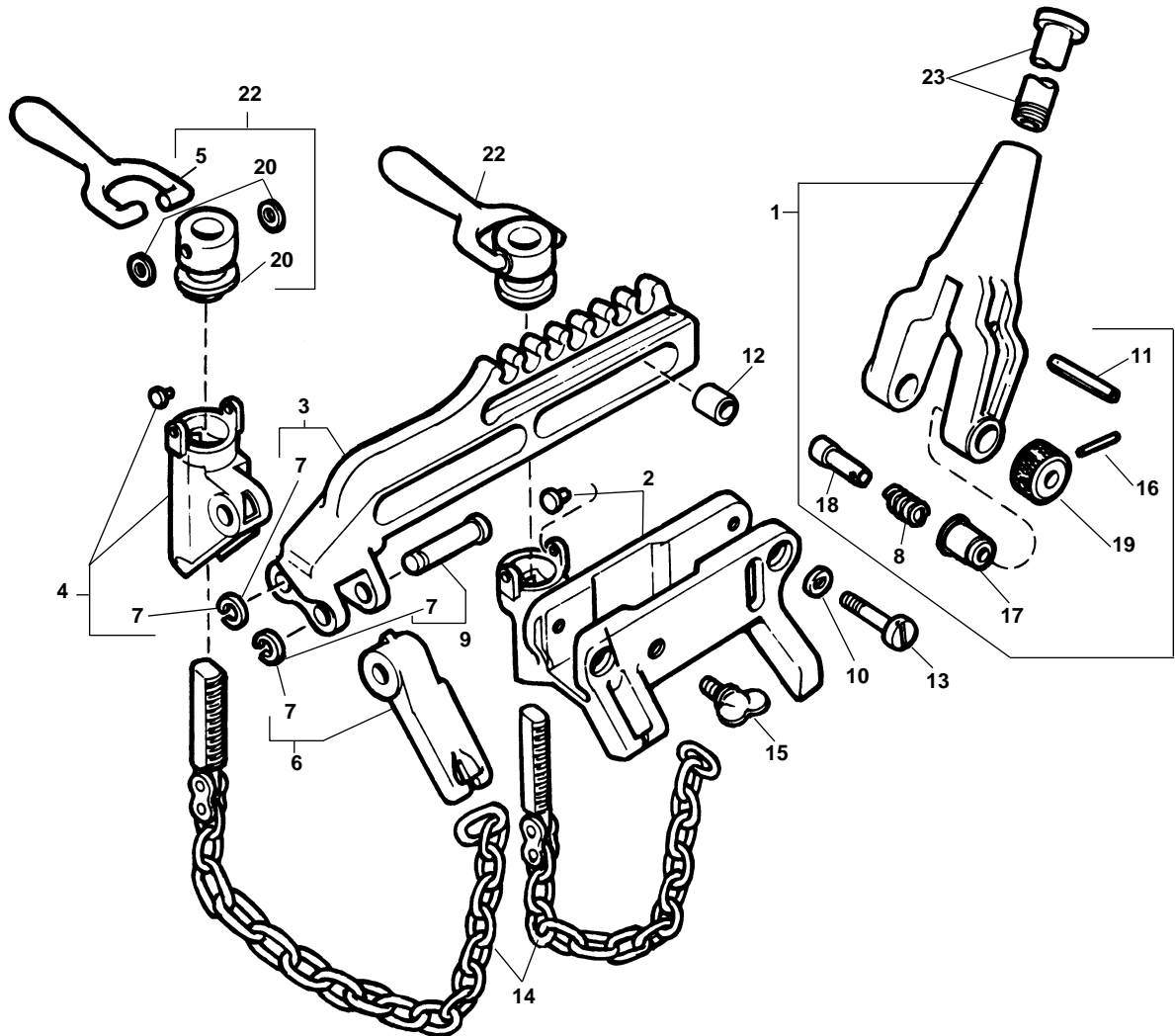

**NOTE: Order parts by Catalog Number only.
DO NOT order by Reference Number.**

Ref. No.	Catalog No.	Description	Ref. No.	Catalog No.	Description
—	32905	228 Soil Pipe Assembly Tool	12	34380	Slide Roller (2)
1	33315	Yoke Assembly	13	34385	Slide Roller Screw (2)
2	33405	Housing w/Pivot Pin	14	34390	Chain and Screw Assembly (2)
3	33410	Slide Assembly	15	34395	Thumb Screw
4	33415	Hinged Jaw Assembly	16	34400	Pin (2)
5	32190	Handle (2)	17	34405	Insert (2)
6	33530	Hinged Hook Assembly	18	34410	Pivot Pin (2)
7	33685	Retaining Ring (2)	19	34415	Knob (2)
8	38695	Coil Spring (2)	20	34430	Washer (4)
9	33775	Hinge Pin Assembly (2)	21	32200	Swivel Nut (2)
10	35530	Lock Washer (2)	22	34795	Handle and Nut Assembly (2)
11	34375	Ratchet Pin	23	47090	Handle

Официальный дистрибьютор в России с 1996 года (921) 936-02-07, (812) 331-37-51