

**Main Components**

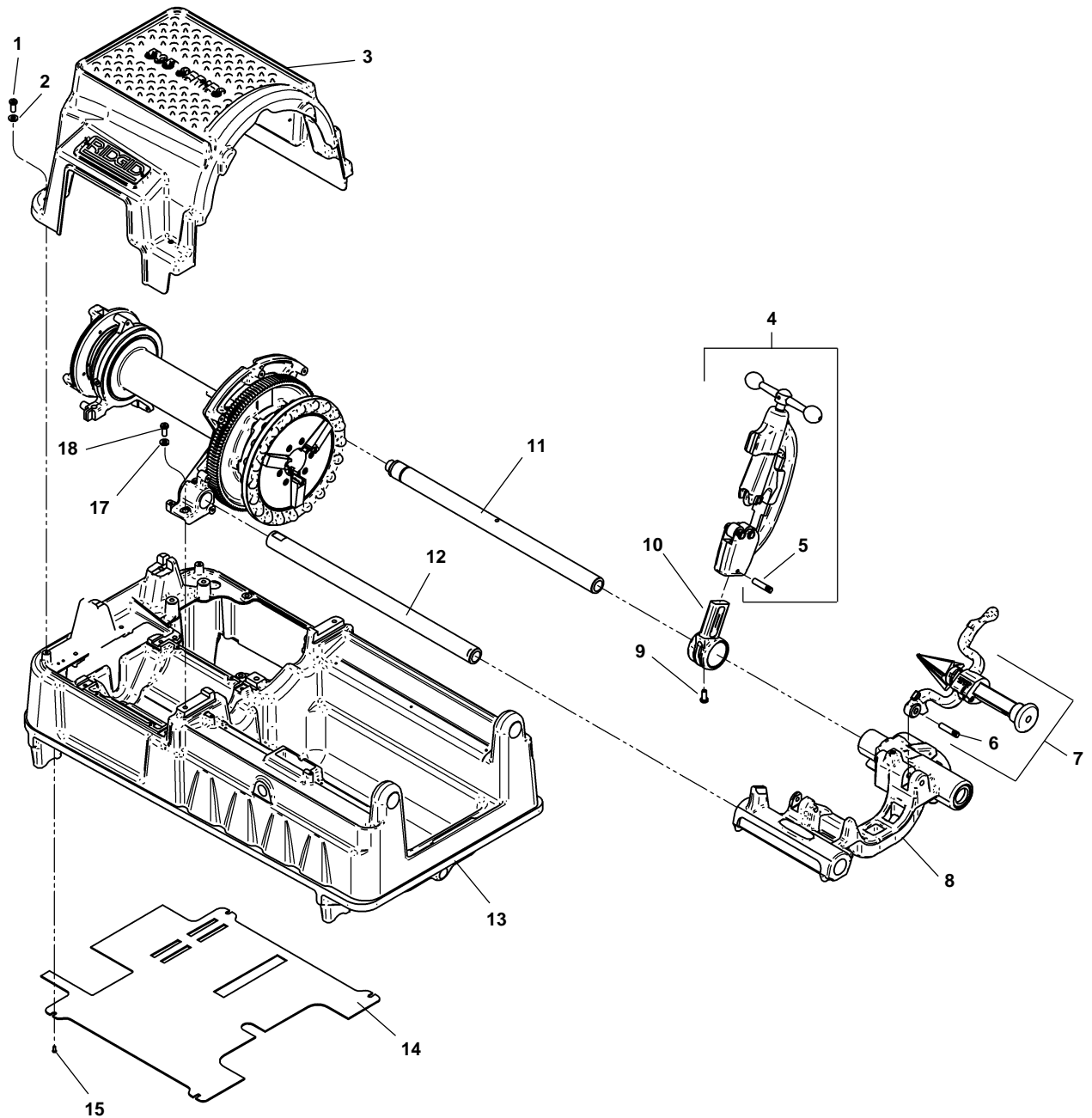

**NOTE: Order parts by Catalog Number only.  
DO NOT order by Reference Number.**

Ref. No.	Catalog No.	Description	Ref. No.	Catalog No.	Description
1	94332	Screw, Button Head 1/4" - 20 x 3/4" (4)	9	44930	Stop Screw
2	94322	Washer, Flat 1/4" (4)	10	43690	Cutter Arm
3	94432	Top Cover	11	45220	Rear Support Bar
4	42390	820 Cutter Assembly	12	45440	Front Support Bar
5	47135	Stop Pin	13	94042	Base
6	47065	Pin	14	96432	Bottom Cover
7	42365	341 Reamer Assembly	15	94312	Screw, Pan Head #6 - 32 x 2" (4)
8	94357	Carriage Assembly			

Официальный дистрибьютор в России с 1996 года (921) 936-02-07, (812) 331-37-51

**Drive Shaft Assembly**

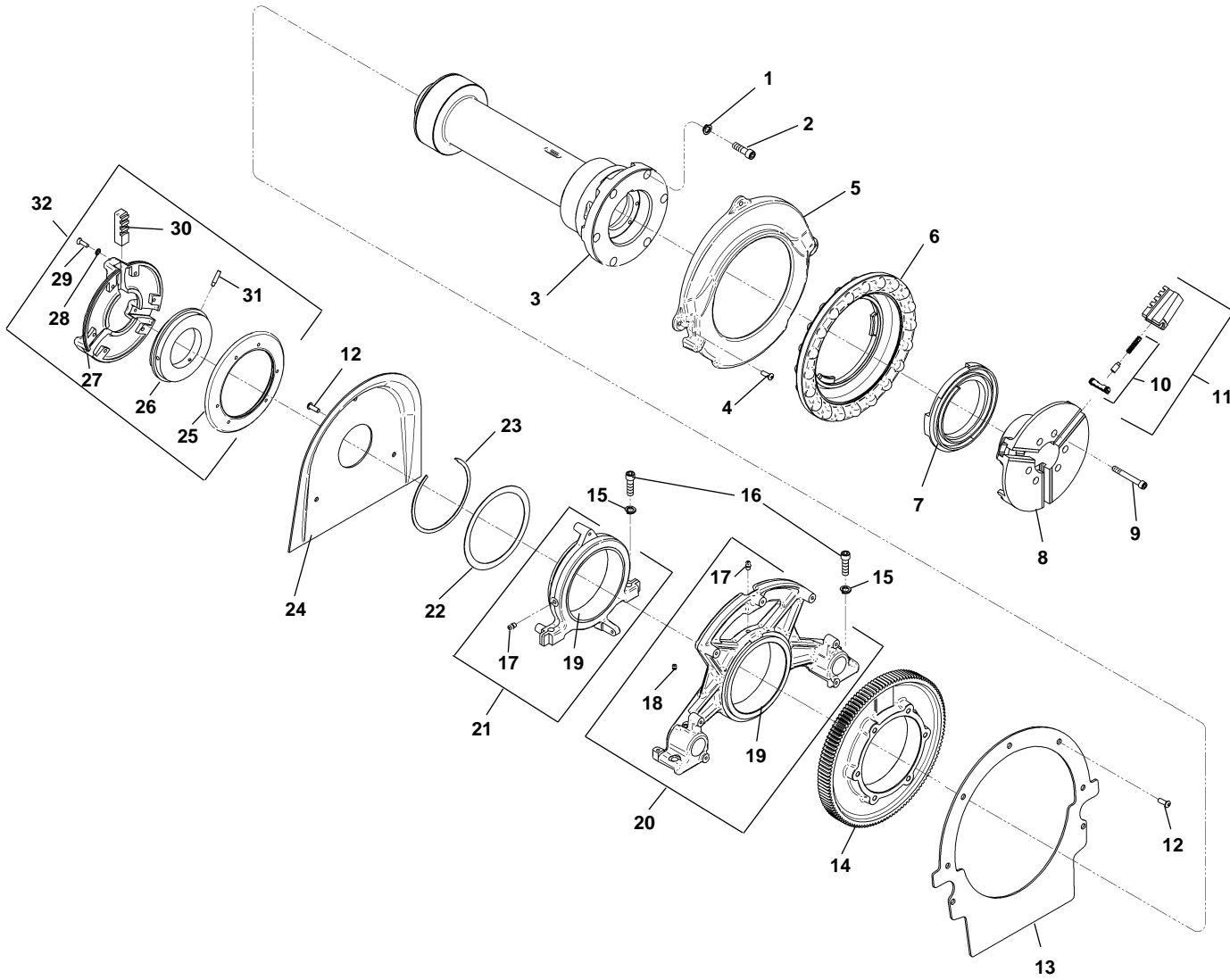

**NOTE: Order parts by Catalog Number only.  
DO NOT order by Reference Number.**

Ref. No.	Catalog No.	Description	Ref. No.	Catalog No.	Description
1	40930	Washer, Lock 3/8"	18	40910	Set Screw 1/4" - 20 x 3/4" (4)
2	46475	Screw, Soc. Hd. 3/8" - 16 x 1 1/4"	19	93957	Spindle Bearing (2)
3	96427	Drive Shaft	20	94027	Front Bracket Assembly
4	94332	Screw, Button Head 1/4" - 20 x 3/4" (9)	21	94037	Rear Bracket Assembly
5	96407	Front Cover	22	94392	Thrust Washer
6	96422	Handwheel	23	94397	Retaining Ring
7	43450	Scroll	24	96487	Rear Cover
8	43440	Chuck Cap	25	43740	Back Plate
9	45295	Screw, 3/16" - 18 x 2 3/4" (6)		19356	Back Plate - Europe
10	44715	Insert Set	26	44095	Scroll
11	44090	Front Jaw (4)	27	43735	Centering Head
12	94337	Screw, Button Head 1/4" - 20 x 3/8" (7)		19346	Centering Head - Europe
13	94072	Front Plate	28	40270	Lock Washer (6)
14	96417	Drive Gear	29	46790	Screw, #12-24 x 3/4" (6)
15	40930	Washer, Lock 3/8" (4)	30	46500	Centering Jaw (3)
16	46745	Screw, 3/8" - 16 x 1 1/4" (4)	31	45260	Step Pin (3)
17	46860	Grease Fitting (2)	32	44165	Centering Head Assembly

Официальный дистрибьютор в России с 1996 года (921) 936-02-07, (812) 331-37-51

**Motor**

**1101**

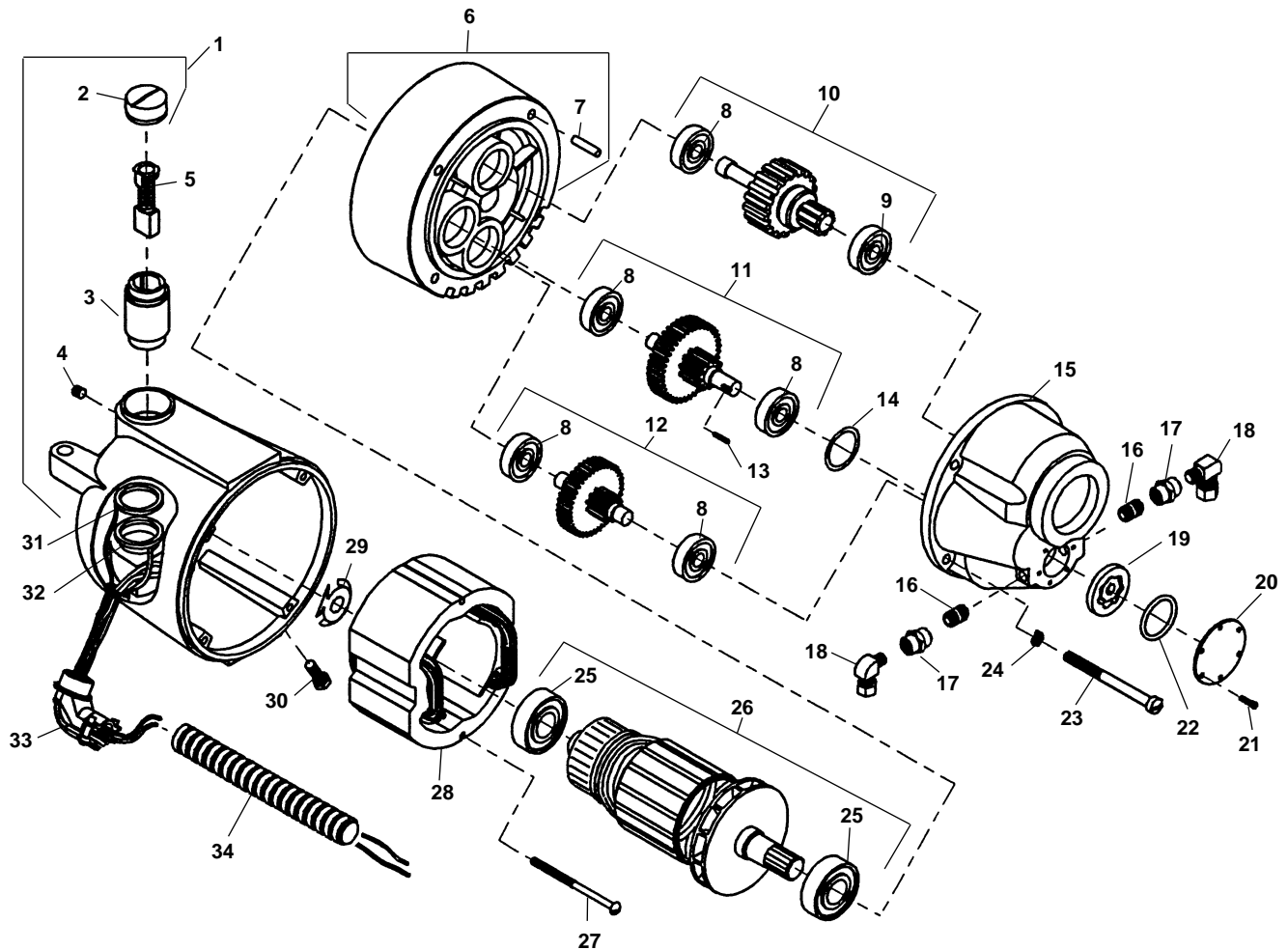

**NOTE: Order parts by Catalog Number only.  
DO NOT order by Reference Number.**

Ref. No.	Catalog No.	Description	Ref. No.	Catalog No.	Description	Ref. No.	Catalog No.	Description
—	96442	1101 Motor 115V	12	45005	2nd Gear Assembly	24	45150	Lock Washer
1	43160	Housing Assembly	13	96885	Pin	25	52517	Male Elbow
2	44545	Brush Cap Set	14	96880	Oil Seal	26	44565	Armature Bearing (2)
3	45025	Brush Holder Set	15	96830	Gear Housing	27	52497	Armature (115V)
4	39770	Set Screw (2)	16	52507	Pipe Nipple 1/8" NPT (2)	27	44555	Mounting Screw (2)
5	44540	Brush Assembly Set	17	52512	Coupling 1/8" NPT (2)	28	44015	Field (115V)
6	54552	Fan Housing Assembly	18	52517	90° Elbow Fitting (2)	29	44580	Loading Spring
7	45165	Dowel Pin	19	96870	Gerotor Set	30	83500	Locking Screw (2)
8	45060	Gear Bearings (5)	20	96840	Cover Plate	31	96942	White Upper Lead
9	45315	Front Bearing	21	96890	Screw (6)	32	96492	Red Lower lead
10	96437	Drive Gear	22	96875	O Ring	33	46900	Connector 90
11	52522	1st Gear Assembly	23	45075	Screw (4)	34	96482	Flexible Conduit

Официальный дистрибьютор в России с 1996 года (921) 936-02-07, (812) 331-37-51

**Oiling Components**

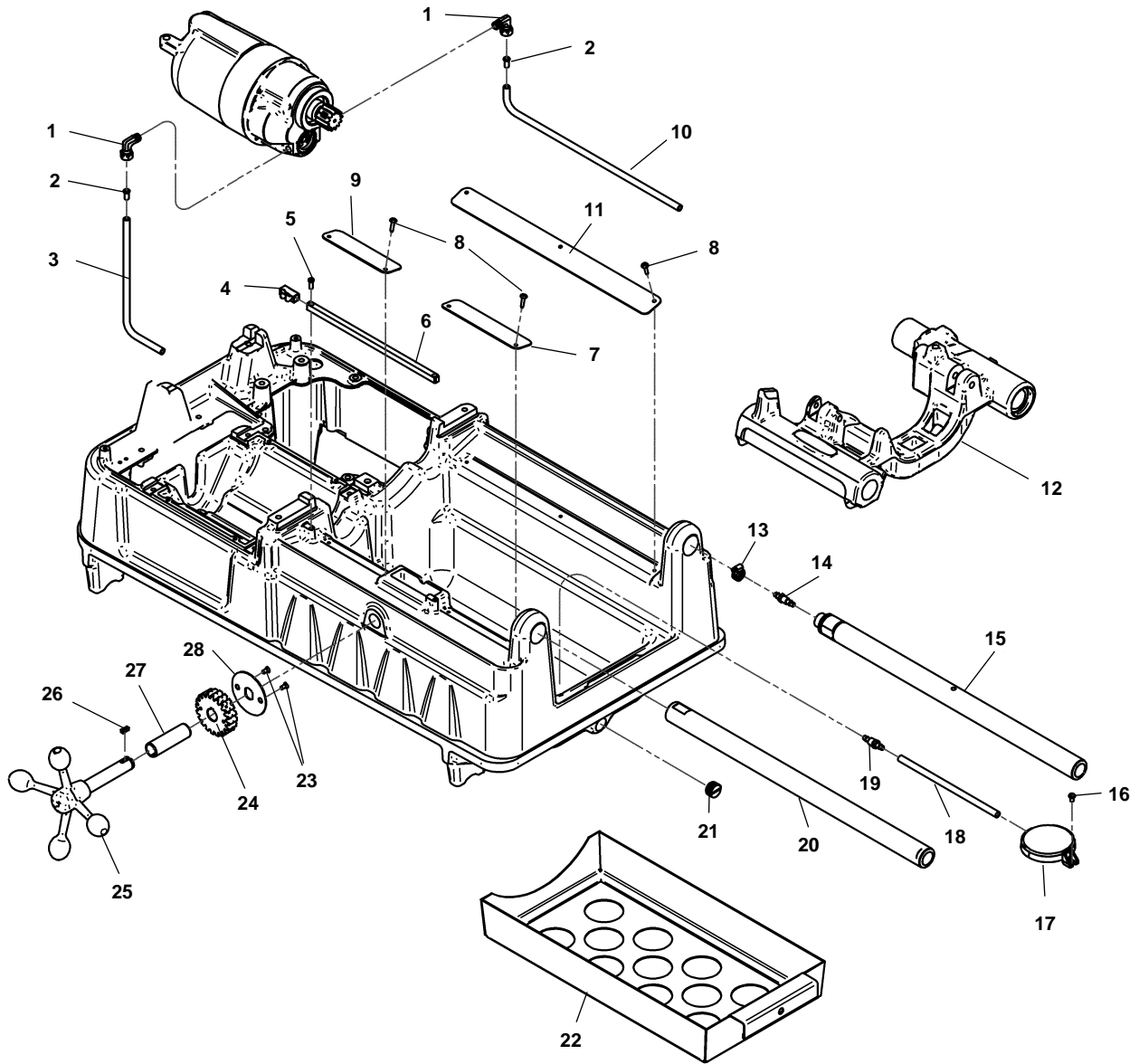

**NOTE: Order parts by Catalog Number only.  
DO NOT order by Reference Number.**

Ref. No.	Catalog No.	Description	Ref. No.	Catalog No.	Description
1	35122	Fitting (2)	15	45220	Support Bar, Rear
2	35117	Tube Insert	16	45420	Screw, #10 - 32 x 3/8"
3	96477	Oil Hose, Input 13"	17	58467	Filter Screen Assembly
4	47110	Indicator Slide	18	87950	Oil Hose, Filter
5	45615	Screw, Flat Head #10 - 32 x 1/2" (2)	19	54142	Bulkhead Fitting
6	47105	Length Indicator Bar	20	45440	Support Bar, Front
7	94117	Drip Edge	21	96447	Drain Plug 1/2" NPT
8	43367	Screw, #8 x 3/4"	22	94112	Chip Tray
9	94122	Drip Edge	23	46785	Screw, Flat Head #10 - 32 x 3/8" (2)
10	58482	Oil Hose, Input 25"	24	45430	Pinion
11	94127	Drip Edge	25	94012	Handwheel
12	94357	Carriage Assembly	26	94267	Key, 3/16" Square x 1/2"
13	35142	Hose Clamp	27	94222	Bushing
14	69167	Barbed Fitting	28	47120	Pinion Lock Ring

Официальный дистрибьютор в России с 1996 года (921) 936-02-07, (812) 331-37-51

**Electrical Components**

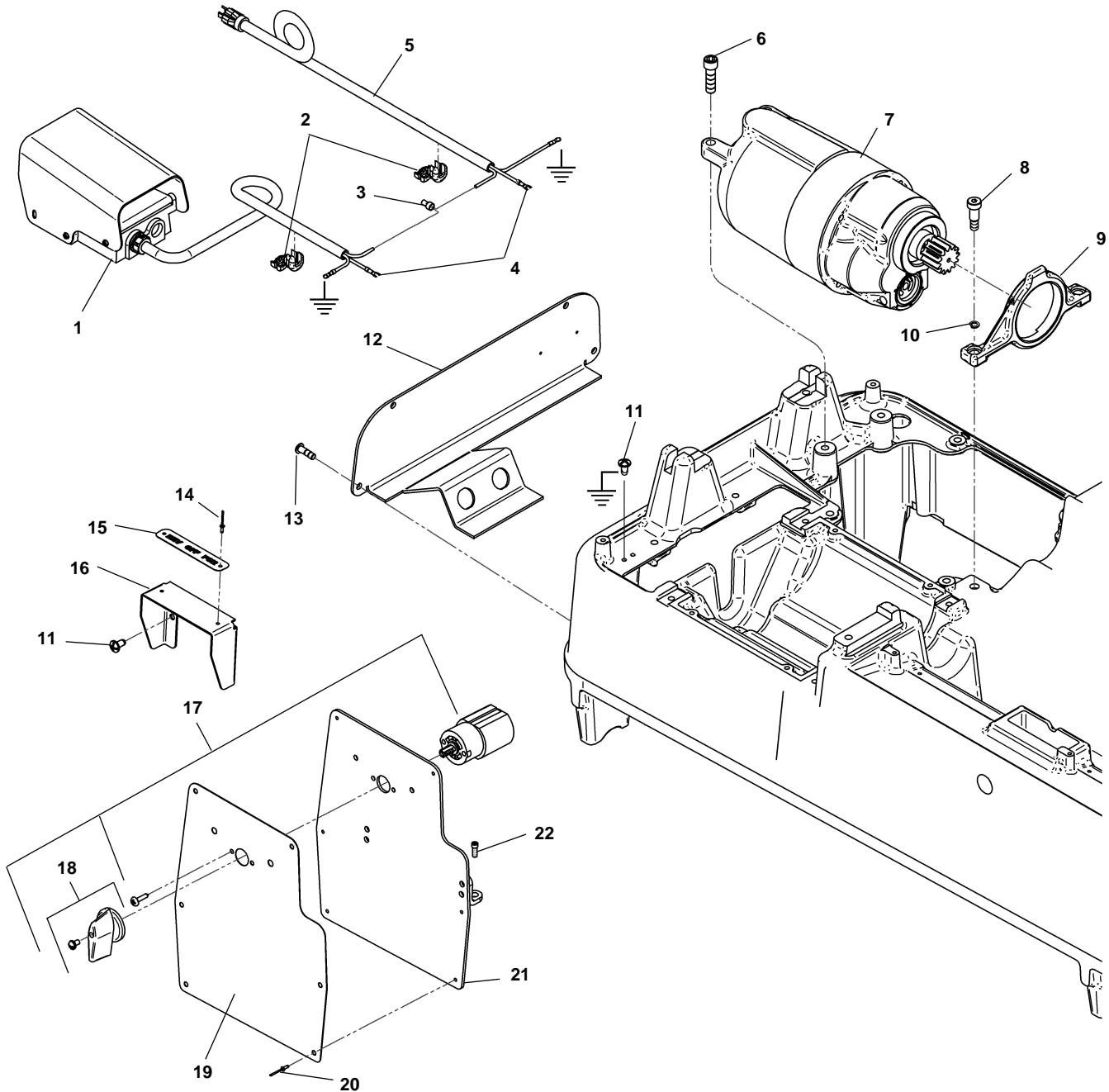

**NOTE: Order parts by Catalog Number only.  
DO NOT order by Reference Number.**

Ref. No.	Catalog No.	Description	Ref. No.	Catalog No.	Description
1	36642	Foot Switch, B-294	12	94152	Back Cover
2	75952	Strain Relief (2)	13	47147	Screw, Button Head #10 - 32 x 3/8" (2)
3	44635	End Splice	14	85920	Pop Rivet (2)
4	46875	Spade Terminal (2)	15	96467	Switch Label
5	75902	Power Cord 115V	16	96452	Switch Cover
6	46745	Screw (2)	17	96462	Switch Assembly
7	96442	Motor	18	59702	Switch Knob
8	36262	Shoulder Bolt (2)	19	96472	Warning Label
9	96402	Motor Bracket	20	94427	Pop Rivet (6)
10	75815	Washer, Lock (2)	21	96457	Control Panel
11	45420	Screw (4)	22	40910	Screw

Официальный дистрибьютор в России с 1996 года (921) 936-02-07, (812) 331-37-51

**B-294 Foot Switch**

**NOTE: Order parts by Catalog Number only.  
DO NOT order by Reference Number.**

Ref. No.	Catalog No.	Description
—	36642	B-294 Foot Switch
—	36647	B-295 Foot Switch
—	36662	301-A Foot Switch
—	75962	B-294 HD Foot Switch
1	36667	Warning Label (B-294)
	36672	Warning Label (B-295)
	36687	Warning Label (301-A)
	76352	Warning Label (B-294 HD)
2	36692	Cover
3	36787	Screw #10 Self-tapping (5)
4	36697	Foot Pedal
5	68880	Cord (B-294)
	36712	Cord (B-295)
	36727	Cord (301-A)
	75972	Cord (B-294 HD)
6	36732	Cord Connector
	75977	Cord Connector (B-294 HD)
7	36702	Spring
8	54347	Base
9	36747	Pivot Pin
10	36767	O-Ring
11	36772	Poppet
12	54367	Insulator
13	36762	Micro Switch
14	54372	Seal
15	54362	Bottom Cover
16	54357	Bottom Cover Screw (4)

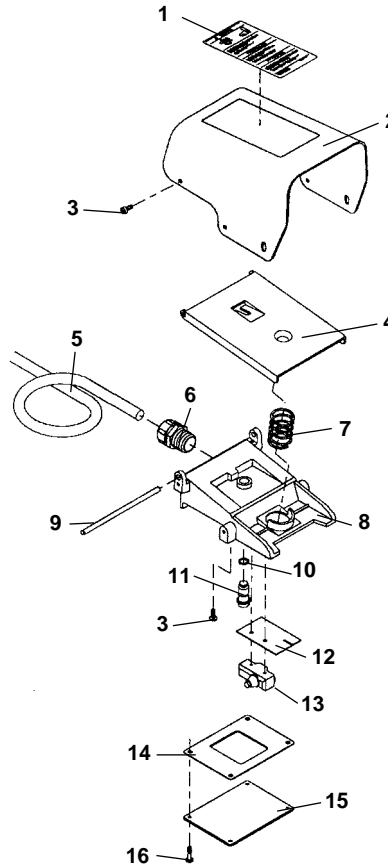

**Wiring Diagram**

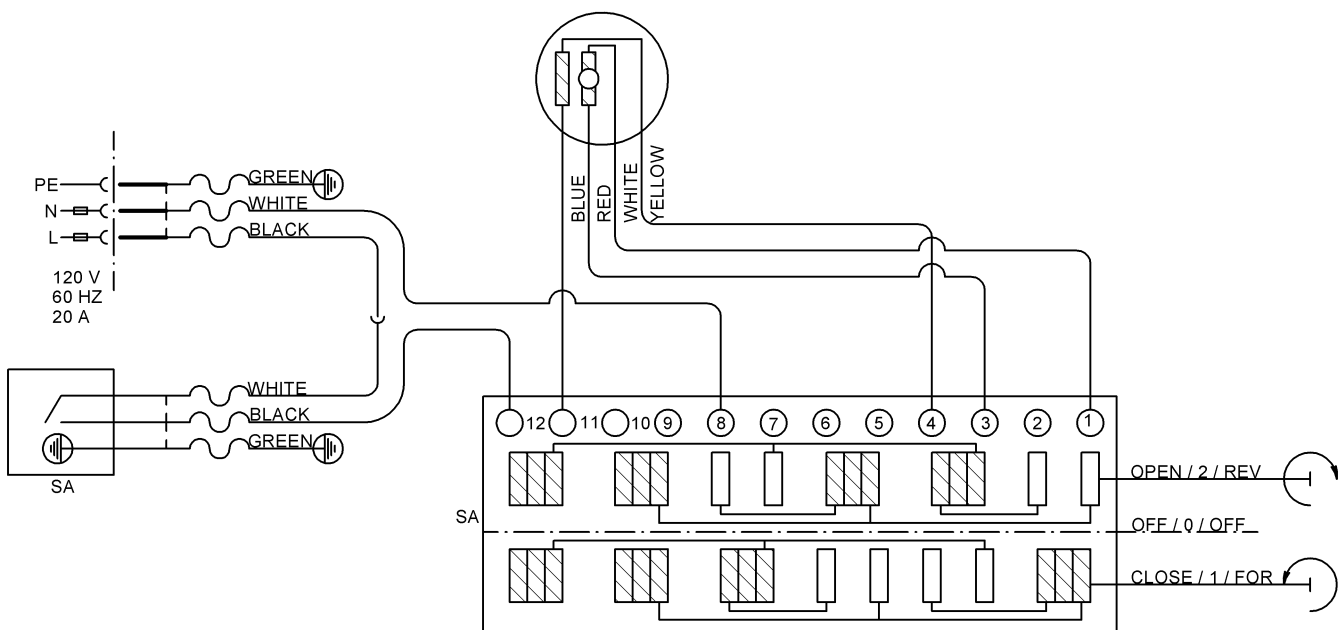

Официальный дистрибьютор в России с 1996 года (921) 936-02-07, (812) 331-37-51

**Carriage**

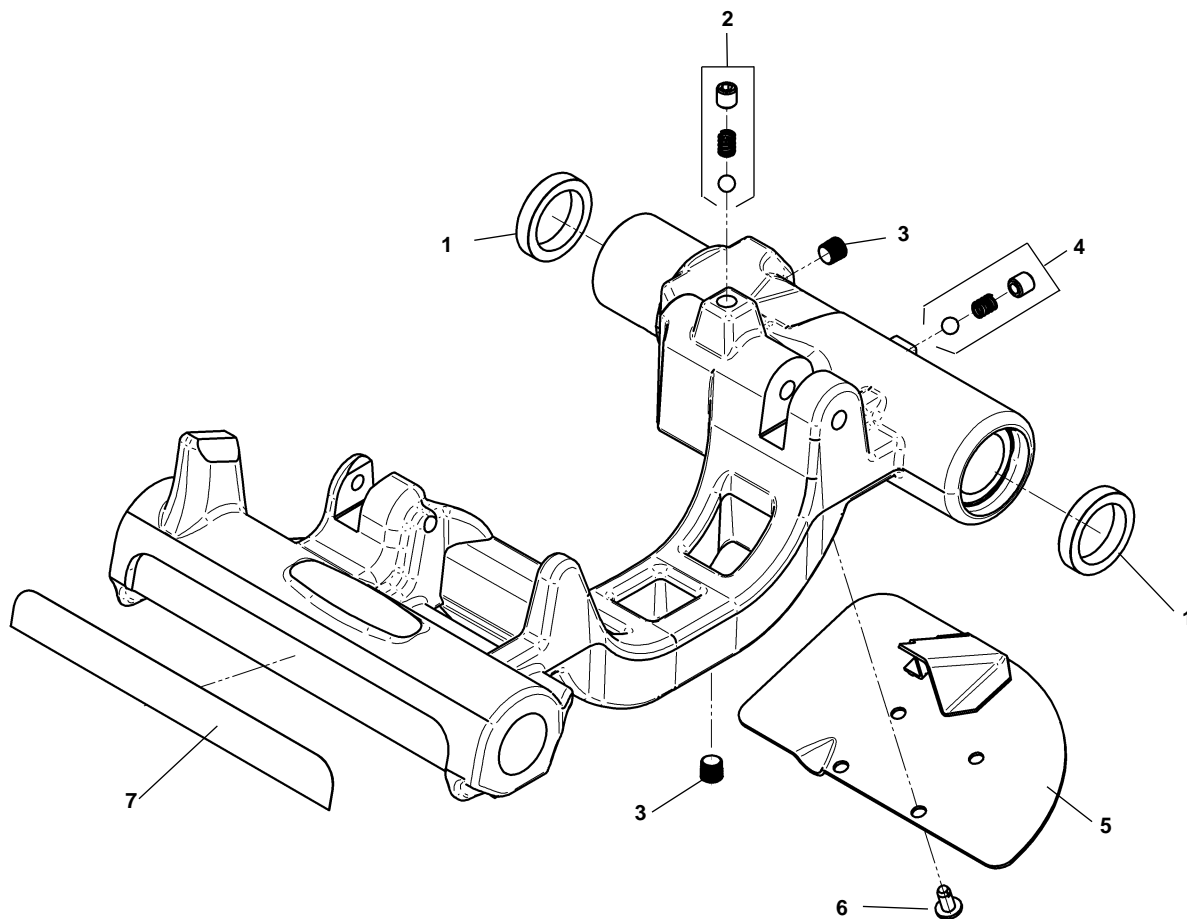

**NOTE: Order parts by Catalog Number only.  
DO NOT order by Reference Number.**

Ref. No.	Catalog No.	Description
—	94357	Carriage Assembly
1	46720	Oil Seal
2	46810	Die Head Détente
3	46815	Pipe Plug, 1/8" NPT (2)
4	35307	Pressure Relief Set
5	45195	Drip Tray
6	46270	Screw, 1/4" - 20 x 1/2" (4)
7	46370	Length Gauge

**No. 341 Reamer**

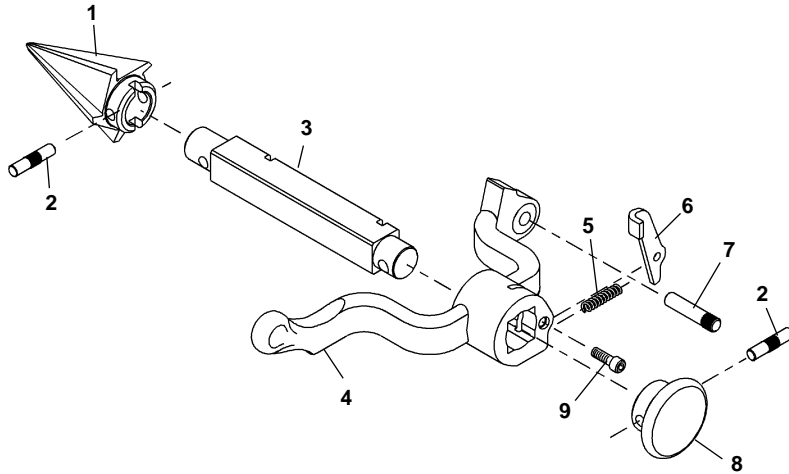

Ref. No.	Catalog No.	Description
—	42365	341 Reamer Complete
1	36277	Cone (R.H.)
	46660	Cone (L.H. & R.H.)
2	47155	Pin
3	43790	Reamer Bar
4	43230	Reamer Arm
5	44700	Latch Spring
6	46665	Reamer Latch
7	47065	Hinge Pin
8	46585	Reamer Knob
9	46515	Screw 1/4" - 20 x 3/4"

**No. 820 Cutter**

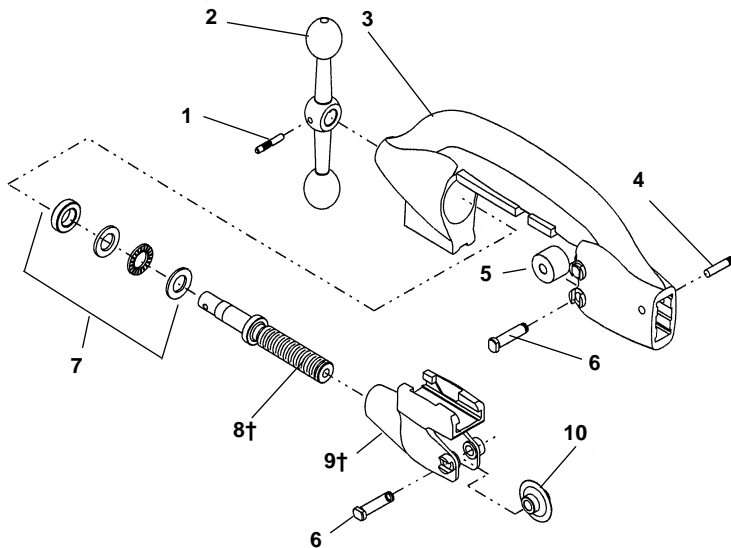

**NOTE: Order parts by Catalog Number only. DO NOT order by Reference Number.**

Ref. No.	Catalog No.	Description
—	42390	820 Cutter Complete
1	47160	Crank Pin
2	45765	Feed Screw Crank
3	43040	Cutter Frame
4	47135	Stop Pin
5	34775	Cutter Roll (2)
6	34780	Cutter & Roll Pin (3)
7	46725	Thrust Bearing Assembly
8†	45780	Feed Screw
9†	43245	Wheel Housing
10	44185	Cutter Wheel
	44190	Cutter Wheel f/Stainless

† Service Note: When replacing parts on early style (fine thread) cutters, both feed screw and wheel housing must be replaced.



**811A  
842  
555  
531B  
532B**

**MONO (A-SERIES)**

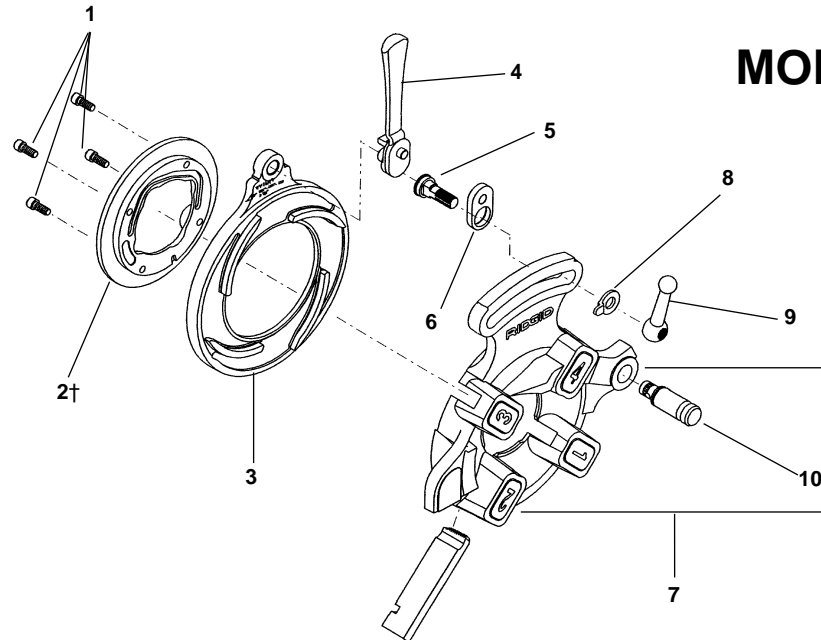
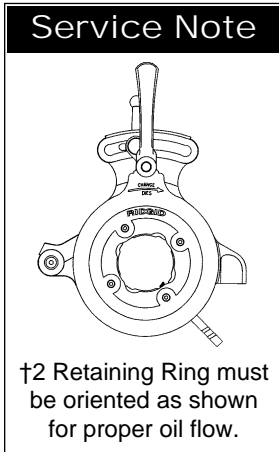

**QUICK OPENING DIE HEADS**

**NOTE: Order parts by Catalog Number only. DO NOT order by Reference Number.**

Ref. No.	1	2†	3	1	5	6	7	8	9	10
Die Head & Catalog No.	Screw	Retaining Ring	Cam Plate	Throw-Out Lever	Lock Screw	Link	Head/w Post	Lever Washer	Clamp Lever	Post
811A (97065) 1/8"-2" RH NPT	32205	97020	43360	46520	39860	39950	40922	26957	39970	59832
842 (23282) 1/8"-2" LH NPT	32205	23292	43360	46520	39860	39950	23287	26957	39970	59832
555 (10491) 1/8"-3/4"	32205	24256	43365	46555	39860	39950	24006	26957	39970	59832
531B (97045) 1/4"-1" RH/LH	32205	46620	43405	46555	39955	39950	97055	26957	39970	59832
532B (97050) 1 1/8"-2" RH/LH	32205	46625	43410	46555	39955	39950	97060	26957	39970	59832
811A (97070) 1/8"-2" BSPT	32205	97020	43360	46520	39860	39950	40957	26957	39970	59832
842 (23297) 1/8"-2" LH (BSPT)	32205	23292	43360	46520	39860	39950	23202	26957	39970	59832
Mono (1/8"-3/8") RH 1/8" (41032) 1/4" (41037) 3/8" (41042)	32205	1/8"-41862 1/4"-41867 3/8"-41872	43305	46555	47140	39950	41907	26957	46820*	59832
Mono (1/2"-3/4") RH 1/2" (41047) 3/4" (41062)	32205	1/2"-41877 3/4"-41882	43300	46555	47140	39950	41912	26957	46820*	59832
Mono (1"-1 1/4") RH 1" (41057) 1 1/4" (41062)	32205	1"-41887 1 1/4"-41892	43295	46555	47140	39950	41917	26957	46820*	59832
Mono (1 1/2"-2") RH 1 1/2" (41067) 2" (41072)	32205	1 1/2"-41897 2"-41902	43290	46555	47140	39950	41922	26957	46820*	59832

\*Hex Nut For Mono Die Heads

Официальный дистрибьютор в России с 1996 года (921) 936-02-07, (812) 331-37-51

**816/817 Die Head**

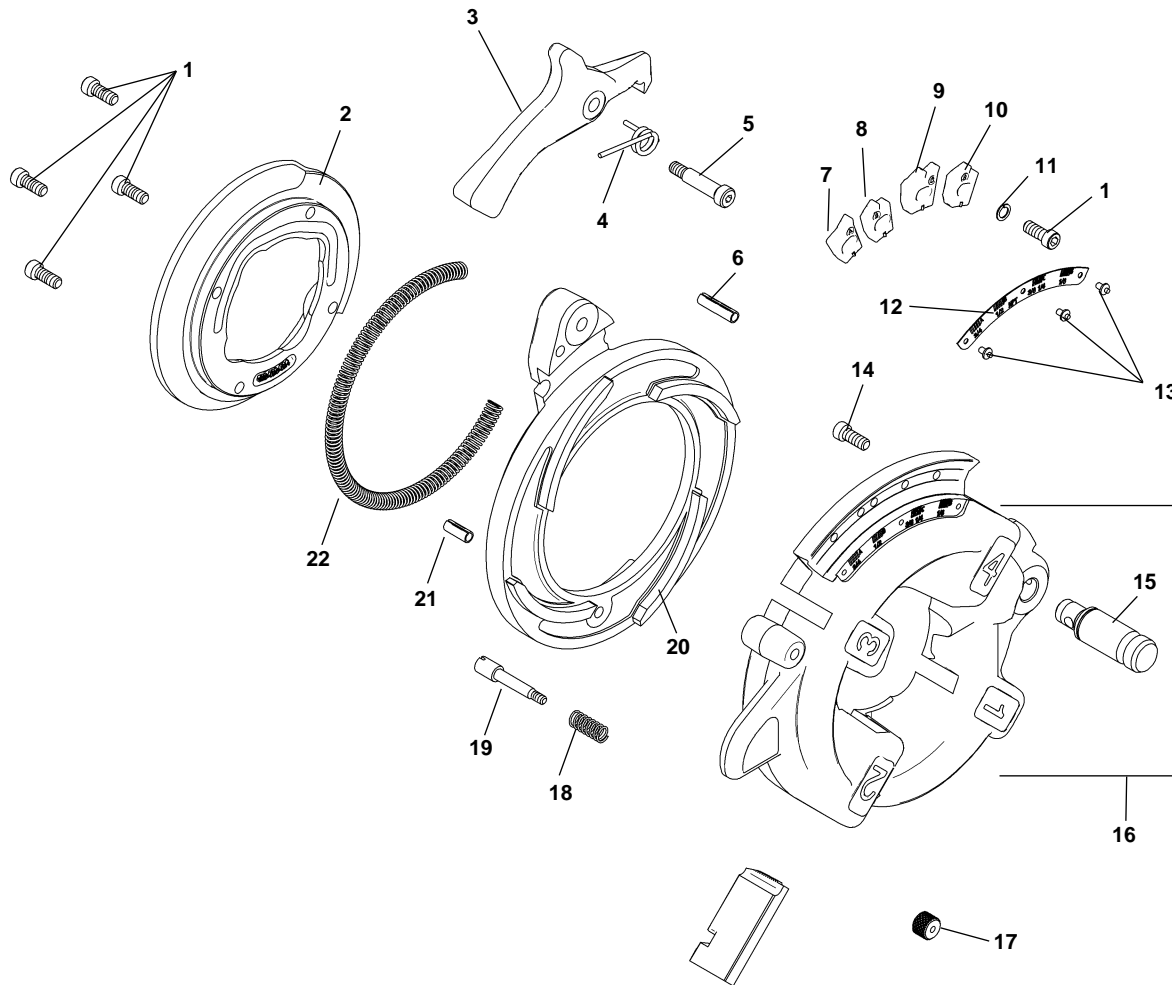

**NOTE: Order parts by Catalog Number only.  
DO NOT order by Reference Number.**

Ref. No.	Catalog No.	Description	Ref. No.	Catalog No.	Description
—	84537	816 Die Head 1/8" - 3/4"	11	44740	Split Lock Washer, 1/4" (4)
—	84532	817 Die Head 1" - 2"	12	92772	Size Plate 816 1/8" - 3/4"
1	40910	Screw, 1/4" - 20 x 3/4" S.H.C.S. (8)		92777	Size Plate 817 1" - 2"
2	92767	Retaining Ring	13	85920	Pop Rivet 3/32" (3)
3	92822	Handle	14	32145	Screw, 1/4" - 20 x 1/2" S.H.C.S.
4	92817	Spring	15	59832	Die Head Post
5	92812	Shoulder Bolt	16	92757	Die Head Body w/Post
6	92832	Roll Pin 1/4" x 5/8"	17	92802	Plunger Knob
7	92782	Adjusting Block 816/817 3/4", 2" Type A	18	92807	Plunger Spring
8	92787	Adjusting Block 816 1/2" Type B	19	92797	Plunger Shaft
	92782	Adjusting Block 817 1 1/2" Type A	20	92762	Cam Plate
9	92792	Adjusting Block 816 1/4", 3/8" Type C	21	58090	Roll Pin 1/4" x 1"
	92787	Adjusting Block 817 1 1/4" Type B	22	92827	Spring
10	92787	Adjusting Block 816/817 1/8", 1" Type B			

Официальный дистрибьютор в России с 1996 года (921) 936-02-07, (812) 331-37-51

**815A NPT Self-Opening Through-Head Oiling Die Head**  
**815A BSPT Self-Opening Through-Head Oiling Die Head**

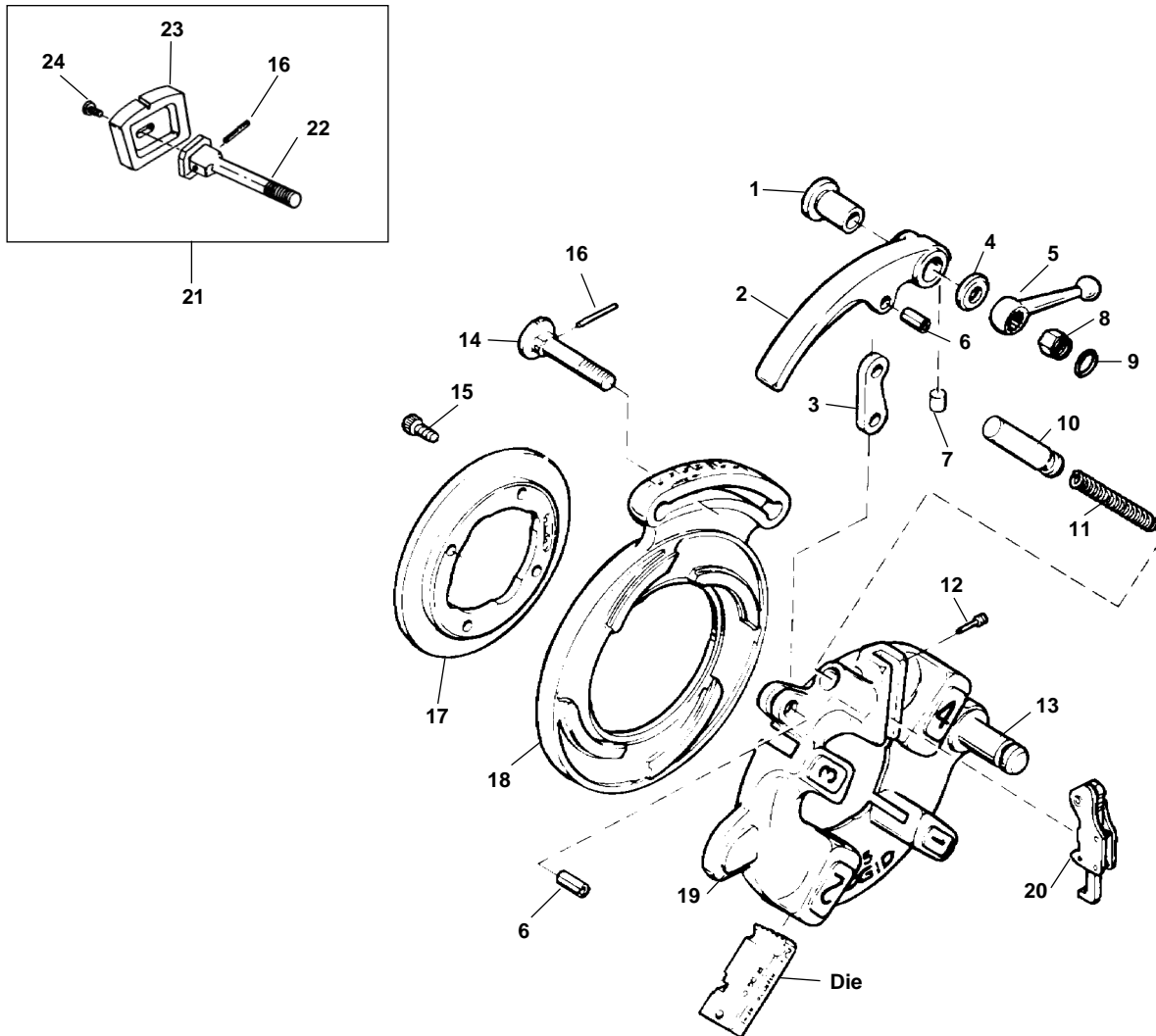

**NOTE: Order parts by Catalog Number only.  
 DO NOT order by Reference Number.**

Ref. No.	Catalog No.	Description	Ref. No.	Catalog No.	Description
—	97075	815A Self-Opening (Through-Head-Oiling) Die Head (NPT)	13	59832	Post
	97080	815A Self-Opening (Through-Head-Oiling) Die Head (BSPT)	14	44235	Lock Screw
1	44240	Bushing	15	32205	Screw (4)
2	43830	Throw-Out Lever	16	45050	Pin
3	44265	Throw-Out Link	17	97020	Retaining Ring
4	44245	Washer	18	40942	Cam Plate (815A NPT)
5	44260	Clamp Lever	19	97040	Cam Plate (815A BSPT)
6	44270	Roll Pin (2)	20	40932	Head w/Post
7	45055	Insert		44285	Trigger Assembly
8	44250	Nut		32982	Adj. Trigger Assembly (Europe)
9	44255	Retaining Ring		45327	Trigger Assembly (Europe)
10	44275	Throw-Out Plunger	21	45332	Gauge Plate Assembly
11	11565	Spring	22	46722	Adj. Lock Screw
12	44290	Trigger Screw	23	46717	Gauge Plate
			24	47147	Buttonhead Screw

Note: Early Style 815/845 parts interchangeable with 815A NPT  
 Early Style 855 parts interchangeable with 815A BSPT

Официальный дистрибьютор в России с 1996 года (921) 936-02-07, (812) 331-37-51

**No. 100A Leg and Tray Stand**

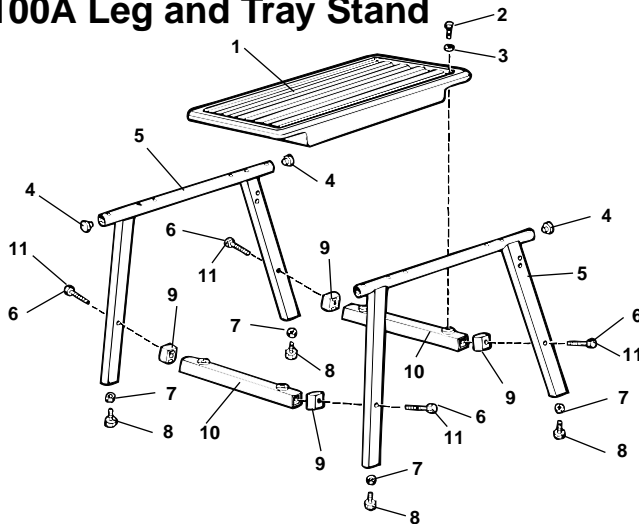

**NOTE: Order parts by Catalog Number only. DO NOT order by Reference Number.**

Ref. No.	Catalog No.	Description
—	92457	Leg Stand Assembly
1	56872	Tray
2	80030	Hex Bolt 3/8" - 16 x 1" (4)
3	44230	Flat Washer 3/8" (4)
4	58037	End cap (4)
5	58022	Leg (2)
6	58052	Hex Bolt 3/8" - 16 x 2 1/2" (4)
7	44225	Hex Nut 3/8" - 16 (4)
8	58027	Leveling Pad (4)
9	58042	Spacer (4) - (1224 Machine Only)
10	58032	Cross Member (2)
11	58047	Hex Bolt 3/8" - 16 x 4" (4) (1224 & 535 Auto Machine Only)

**NOTE: 3/8" - 16 x 4" Bolts and spacers used when mounting 1224 & 535 Auto machines.**

**No. 150A Wheel and Tray Stand**

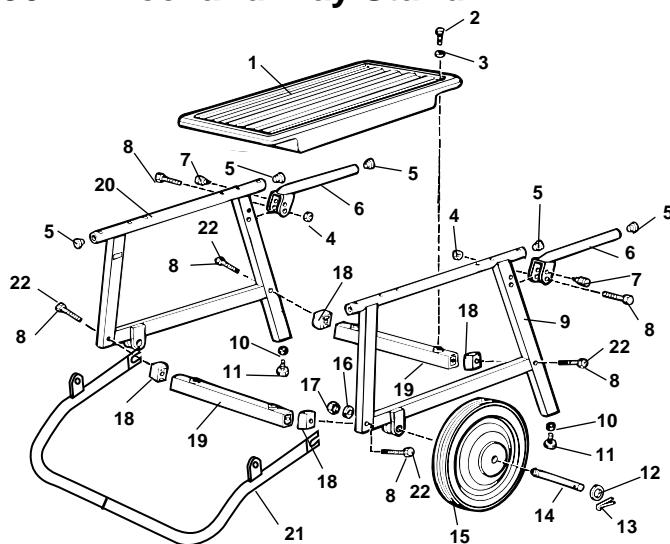

Ref. No.	Catalog No.	Description
—	92462	Wheel and Tray Assembly
1	56872	Tray
2	80030	Hex Bolt 3/8" - 16 x 1" (4)
3	44230	Flat Washer (4)
4	79985	Locknut 3/8" - 16 (2)
5	58037	End Cap (6)
6	58067	Handle (2) includes Ref. No. 5 & 7
7	61567	Plunger Assembly (2)
8	58052	Hex Bolt 3/8" - 16 x 2 1/2" (6)
9	58057	Front Leg
10	44225	Hex Nut 3/8" - 16 (4)
11	58027	Leveling Pad
12	47180	Washer (2)
13	47030	Cotter Pin (2)
14	58072	Axle (2)
15	27442	Wheel (2)
16	84150	Lock Washer 1/2" (2)
17	44745	Locknut 1/2" (2)
18	58042	Spacer (4) (1224 machine only)
19	58032	Cross Member (2)
20	58062	Rear Leg
21	63652	Stand Stop Assembly
22	58047	Hex Bolt 3/8" - 16 x 4" (4) (1224 & 535 Automatic Machine Only)

**NOTE: 3/8" - 16 x 4" bolts and spacers used when mounting 1224 & 535 Auto machines.**

**No. 200A Wheel and Cabinet Stand**

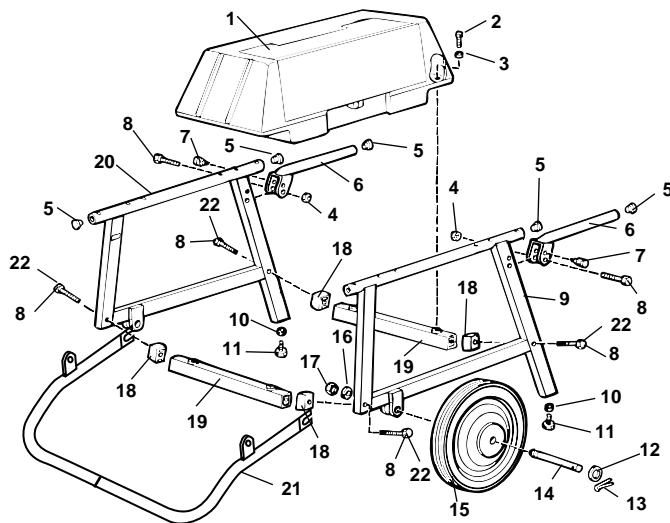

Ref. No.	Catalog No.	Description
—	92467	Wheel Stand Assembly
1	56887	Cabinet
2	80030	Hex Bolt 3/8" - 16 x 1" (4)
3	44230	Flat Washer (4)
4	79985	Locknut 3/8" - 16 (2)
5	58037	End Cap (6)
6	58067	Handle (2) Includes Ref. No. 5 & 7
7	61567	Plunger Assembly (2)
8	58052	Hex Bolt 3/8" - 16 x 2 1/2" (6)
9	58057	Front Leg
10	44225	Hex Nut 3/8" - 16 (4)
11	58027	Leveling Pad
12	47180	Washer (2)
13	47030	Cotter Pin (2)
14	58072	Axle (2)
15	27442	Wheel (2)
16	84150	Lock Washer 1/2" (2)
17	44745	Locknut 1/2" (2)
18	58042	Spacer (4) (1224 Machine Only)
19	58032	Cross Member (2)
20	58062	Rear Leg
21	63652	Stand Stop Assembly
22	58047	Hex Bolt 3/8" - 16 x 4" (4) (1224 & 535 Auto Machine Only)

**NOTE: 3/8" - 16 x 4" bolts and spacers used when mounting 1224 & 535 Auto machines.**